

Operating Instructions

Ultrasonic sensor for continuous level measurement

VEGASON 61

Two-wire 4 ... 20 mA/HART



Document ID: 28775



VEGA

Contents

1	About this document	4
1.1	Function	4
1.2	Target group	4
1.3	Symbols used.....	4
2	For your safety	5
2.1	Authorised personnel	5
2.2	Appropriate use.....	5
2.3	Warning about incorrect use.....	5
2.4	General safety instructions	5
2.5	Safety label on the instrument	6
2.6	EU conformity.....	6
2.7	Fulfillment of NAMUR recommendations	6
2.8	Installation and operation in the USA and Canada	6
2.9	Environmental instructions	6
3	Product description	8
3.1	Configuration.....	8
3.2	Principle of operation.....	9
3.3	Packaging, transport and storage.....	9
3.4	Accessories and replacement parts	10
4	Mounting	12
4.1	General instructions	12
4.2	Mounting instructions	14
5	Connecting to power supply	21
5.1	Preparing the connection	21
5.2	Connection procedure.....	22
5.3	Wiring plan, single chamber housing.....	23
5.4	Wiring plan, double chamber housing	24
5.5	Wiring plan - version IP 66/IP 68 (1 bar)	26
5.6	Switch-on phase.....	27
6	Set up with the display and adjustment module PLICSCOM	28
6.1	Insert display and adjustment module	28
6.2	Adjustment system	29
6.3	Setup steps	30
6.4	Menu schematic.....	42
6.9	Saving the parameterisation data	43
7	Set up with PACTware and other adjustment programs	44
7.1	Connect the PC via VEGACONNECT	44
7.2	Parameter adjustment with PACTware.....	45
7.3	Parameter adjustment with AMS™ and PDM.....	46
7.4	Saving the parameterisation data	47
8	Maintenance and fault rectification	48
8.1	Maintenance	48
8.2	Rectify faults.....	48
8.3	Exchanging the electronics module.....	49
8.4	Software update	50

8.5	How to proceed if a repair is necessary.....	50
9	Dismount.....	51
9.1	Dismounting steps.....	51
9.2	Disposal	51
10	Supplement	52
10.1	Technical data	52
10.2	Dimensions	57
10.3	Industrial property rights.....	59
10.4	Trademark	59



Safety instructions for Ex areas

Take note of the Ex specific safety instructions for Ex applications. These instructions are attached as documents to each instrument with Ex approval and are part of the operating instructions.

Editing status: 2019-03-12

1 About this document

1.1 Function

This operating instructions provides all the information you need for mounting, connection and setup as well as important instructions for maintenance, fault rectification, the exchange of parts and the safety of the user. Please read this information before putting the instrument into operation and keep this manual accessible in the immediate vicinity of the device.

1.2 Target group

This operating instructions manual is directed to trained personnel. The contents of this manual must be made available to the qualified personnel and implemented.

1.3 Symbols used



Document ID

This symbol on the front page of this instruction refers to the Document ID. By entering the Document ID on www.vega.com you will reach the document download.



Information, tip, note

This symbol indicates helpful additional information.



Caution: If this warning is ignored, faults or malfunctions can result.



Warning: If this warning is ignored, injury to persons and/or serious damage to the instrument can result.



Danger: If this warning is ignored, serious injury to persons and/or destruction of the instrument can result.



Ex applications

This symbol indicates special instructions for Ex applications.



List

The dot set in front indicates a list with no implied sequence.



Action

This arrow indicates a single action.



Sequence of actions

Numbers set in front indicate successive steps in a procedure.



Battery disposal

This symbol indicates special information about the disposal of batteries and accumulators.

2 For your safety

2.1 Authorised personnel

All operations described in this documentation must be carried out only by trained, qualified personnel authorised by the plant operator.

During work on and with the device, the required personal protective equipment must always be worn.

2.2 Appropriate use

VEGASON 61 is a sensor for continuous level measurement.

You can find detailed information about the area of application in chapter "*Product description*".

Operational reliability is ensured only if the instrument is properly used according to the specifications in the operating instructions manual as well as possible supplementary instructions.

For safety and warranty reasons, any invasive work on the device beyond that described in the operating instructions manual may be carried out only by personnel authorised by the manufacturer. Arbitrary conversions or modifications are explicitly forbidden.

2.3 Warning about incorrect use

Inappropriate or incorrect use of the instrument can give rise to application-specific hazards, e.g. vessel overflow or damage to system components through incorrect mounting or adjustment. Thus damage to property, to persons or environmental contamination can be caused. Also the protective characteristics of the instrument can be influenced.

2.4 General safety instructions

This is a state-of-the-art instrument complying with all prevailing regulations and directives. The instrument must only be operated in a technically flawless and reliable condition. The operator is responsible for the trouble-free operation of the instrument. When measuring aggressive or corrosive media that can cause a dangerous situation if the instrument malfunctions, the operator has to implement suitable measures to make sure the instrument is functioning properly.

During the entire duration of use, the user is obliged to determine the compliance of the necessary occupational safety measures with the current valid rules and regulations and also take note of new regulations.

The safety instructions in this operating instructions manual, the national installation standards as well as the valid safety regulations and accident prevention rules must be observed by the user.

For safety and warranty reasons, any invasive work on the device beyond that described in the operating instructions manual may be carried out only by personnel authorised by the manufacturer. Arbitrary conversions or modifications are explicitly forbidden. For safety

reasons, only the accessory specified by the manufacturer must be used.

To avoid any danger, the safety approval markings and safety tips on the device must also be observed and their meaning read in this operating instructions manual.

2.5 Safety label on the instrument

The safety approval markings and safety tips on the device must be observed.

2.6 EU conformity

The device fulfils the legal requirements of the applicable EU directives. By affixing the CE marking, we confirm the conformity of the instrument with these directives.

You can find the EU conformity declaration on our website under www.vega.com/downloads.

2.7 Fulfillment of NAMUR recommendations

NAMUR is the automation technology user association in the process industry in Germany. The published NAMUR recommendations are accepted as the standard in field instrumentation.

The device fulfils the requirements of the following NAMUR recommendations:

- NE 21: 2012 – Electromagnetic compatibility of equipment
- NE 43 – Signal level for fault information from measuring transducers
- NE 53 – Compatibility of field devices and display/adjustment components

For further information see www.namur.de.

2.8 Installation and operation in the USA and Canada

This information is only valid for USA and Canada. Hence the following text is only available in the English language.

Installations in the US shall comply with the relevant requirements of the National Electrical Code (ANSI/NFPA 70).

Installations in Canada shall comply with the relevant requirements of the Canadian Electrical Code.

2.9 Environmental instructions

Protection of the environment is one of our most important duties. That is why we have introduced an environment management system with the goal of continuously improving company environmental protection. The environment management system is certified according to DIN EN ISO 14001.

Please help us fulfil this obligation by observing the environmental instructions in this manual:

- Chapter "*Packaging, transport and storage*"
- Chapter "*Disposal*"

3 Product description

3.1 Configuration

Scope of delivery

The scope of delivery encompasses:

- Ultrasonic sensor
- Documentation
 - Quick setup guide VEGASON 61
 - Instructions for optional instrument features
 - Ex-specific "Safety instructions" (with Ex versions)
 - If necessary, further certificates



Information:

Optional instrument features are also described in this operating instructions manual. The respective scope of delivery results from the order specification.

Constituent parts

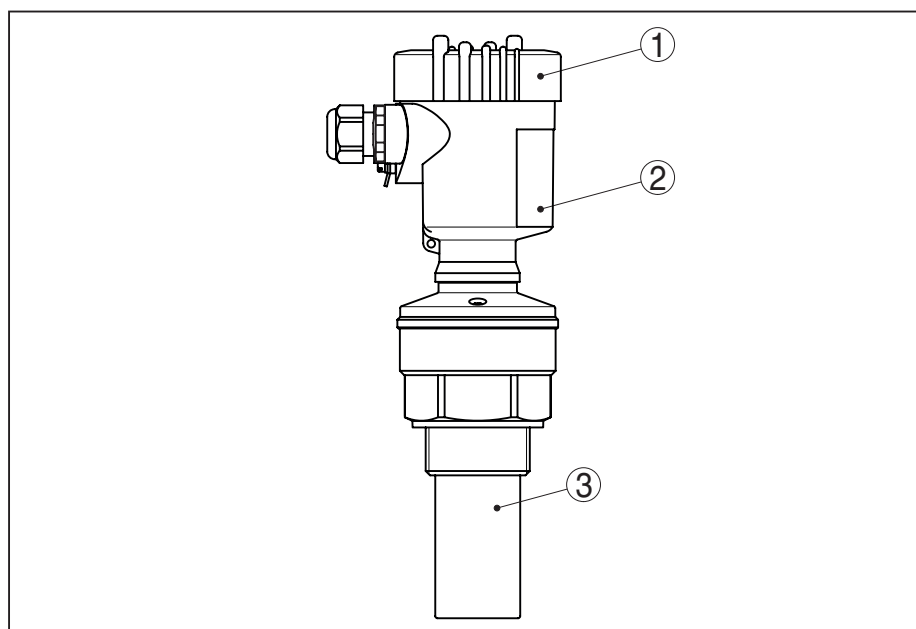

Fig. 1: VEGASON 61, version with plastic housing

- 1 Housing cover with integrated PLICSCOM (optional)
- 2 Housing with electronics, optionally available with plug connector
- 3 Process fitting with transducer

The VEGASON 61 consists of the components:

- Transducer with integrated temperature sensor
- Housing with electronics, optionally available with plug connector
- Housing cover, optionally available with display and adjustment module PLICSCOM

The components are available in different versions.

Type label

The type label contains the most important data for identification and use of the instrument:

- Instrument type
- Article and serial number device
- Article numbers, documentation

- Technical data: For example approvals, process temperature, process fitting/material, signal output, voltage supply, protection
- SIL identification (with SIL rating ex works)

With the serial number, you can access the delivery data of the instrument via "www.vega.com", "Search". You can find the serial number on the inside of the instrument as well as on the type label on the outside.

Scope of this operating instructions

This operating instructions manual applies to the following instrument versions:

- Hardware version from 2.0.0
- Software version from 3.9

3.2 Principle of operation

Application area

VEGASON 61 is an ultrasonic sensor for continuous level measurement. It is suitable for liquids and solids in virtually all industries, particularly in the water and waste water industry.

Functional principle

The transducer of the ultrasonic sensor transmits short ultrasonic pulses to the measured product. These pulses are reflected by product surface and received back by the transducer as echoes. The running time of the ultrasonic pulses from emission to reception is proportional to the distance and hence the level. The determined level is converted into an appropriate output signal and outputted as measured value.

Voltage supply

4 ... 20 mA/HART two-wire electronics for voltage supply and measured value transmission on the same cable.

The supply voltage range can differ depending on the instrument version.

The data for power supply are specified in chapter "*Technical data*".

The backlight of the display and adjustment module is powered by the sensor. The prerequisite for this is a supply voltage at a certain level. The exact voltage specifications are stated in chapter "*Technical data*".

The optional heating requires its own voltage supply. You can find further details in the supplementary instructions manual "*Heating for display and adjustment module*".

This function is generally not available for approved instruments.

3.3 Packaging, transport and storage

Packaging

Your instrument was protected by packaging during transport. Its capacity to handle normal loads during transport is assured by a test based on ISO 4180.

The packaging of standard instruments consists of environment-friendly, recyclable cardboard. For special versions, PE foam or PE foil is also used. Dispose of the packaging material via specialised recycling companies.

Transport	Transport must be carried out in due consideration of the notes on the transport packaging. Nonobservance of these instructions can cause damage to the device.
Transport inspection	The delivery must be checked for completeness and possible transit damage immediately at receipt. Ascertained transit damage or concealed defects must be appropriately dealt with.
Storage	<p>Up to the time of installation, the packages must be left closed and stored according to the orientation and storage markings on the outside.</p> <p>Unless otherwise indicated, the packages must be stored only under the following conditions:</p> <ul style="list-style-type: none"> ● Not in the open ● Dry and dust free ● Not exposed to corrosive media ● Protected against solar radiation ● Avoiding mechanical shock and vibration
Storage and transport temperature	<ul style="list-style-type: none"> ● Storage and transport temperature see chapter "<i>Supplement - Technical data - Ambient conditions</i>" ● Relative humidity 20 ... 85 %
Lifting and carrying	With instrument weights of more than 18 kg (39.68 lbs) suitable and approved equipment must be used for lifting and carrying.
3.4 Accessories and replacement parts	
PLICSCOM	<p>The display and adjustment module PLICSCOM is used for measured value indication, adjustment and diagnosis.</p> <p>The integrated Bluetooth module (optional) enables wireless adjustment via standard adjustment devices.</p>
VEGACONNECT	The interface adapter VEGACONNECT enables the connection of communication-capable instruments to the USB interface of a PC.
VEGADIS 81	The VEGADIS 81 is an external display and adjustment unit for VEGAplics® sensors.
VEGADIS 82	VEGADIS 82 is suitable for measured value indication and adjustment of sensors with HART protocol. It is looped into the 4 ... 20 mA/HART signal cable.
PLICSMOBILE T81	The PLICSMOBILE T81 is an external GSM/GPRS/UMTS radio unit for transmission of measured values and for remote parameter adjustment of HART sensors.
Protective cover	The protective cover protects the sensor housing against soiling and intense heat from solar radiation.

Flanges

Screwed flanges are available in different versions according to the following standards: DIN 2501, EN 1092-1, BS 10, ASME B 16.5, JIS B 2210-1984, GOST 12821-80.

4 Mounting

4.1 General instructions

Suitability for the process conditions

Make sure that all parts of the instrument coming in direct contact with the process, especially the sensor element, process seal and process fitting, are suitable for the existing process conditions, such as process pressure, process temperature as well as the chemical properties of the medium.

You can find the specifications in chapter "*Technical data*" and on the nameplate.

Suitability for the ambient conditions

The instrument is suitable for standard and extended ambient conditions acc. to DIN/EN/IEC/ANSI/ISA/UL/CSA 61010-1.

Installation position

Select an installation position you can easily reach for mounting and connecting as well as later retrofitting of a display and adjustment module. The housing can be rotated by 330° without the use of any tools. You can also install the display and adjustment module in four different positions (each displaced by 90°).

Moisture

Use the recommended cables (see chapter "*Connecting to power supply*") and tighten the cable gland.

You can give your instrument additional protection against moisture penetration by leading the connection cable downward in front of the cable gland. Rain and condensation water can thus drain off. This applies mainly to outdoor mounting as well as installation in areas where high humidity is expected (e.g. through cleaning processes) or on cooled or heated vessels.

To maintain the housing protection, make sure that the housing lid is closed during operation and locked, if necessary.

Make sure that the degree of contamination specified in chapter "*Technical data*" meets the existing ambient conditions.

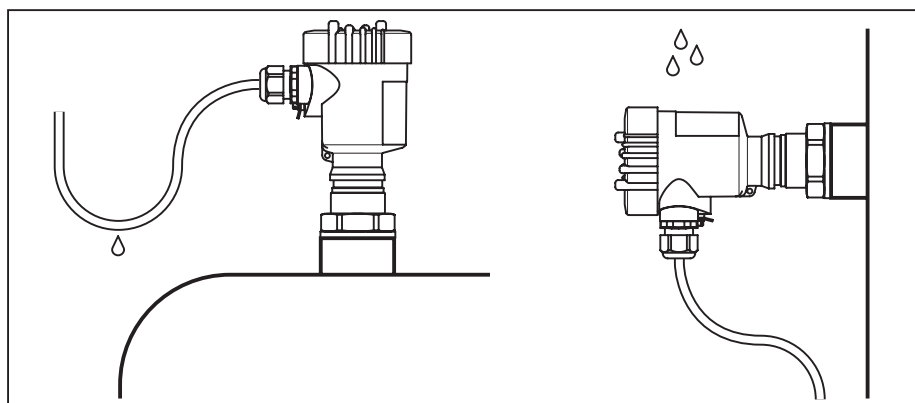

Fig. 2: Measures against moisture ingress

Cable entries - NPT thread Cable glands

Metric threads

In the case of instrument housings with metric thread, the cable glands are screwed in at the factory. They are sealed with plastic plugs as transport protection.

You have to remove these plugs before electrical connection.

NPT thread

In the case of instrument housings with self-sealing NPT threads, it is not possible to have the cable entries screwed in at the factory. The free openings for the cable glands are therefore covered with red dust protection caps as transport protection.

Prior to setup you have to replace these protective caps with approved cable glands or close the openings with suitable blind plugs.

Reference plane for measuring range

The reference plane for the measuring range is the lower edge of the transducer.

Make sure that a minimum distance from the reference plane - the so-called dead zone, in which measurement is not possible - is maintained. The exact value of the dead zone is stated in chapter "Technical data".

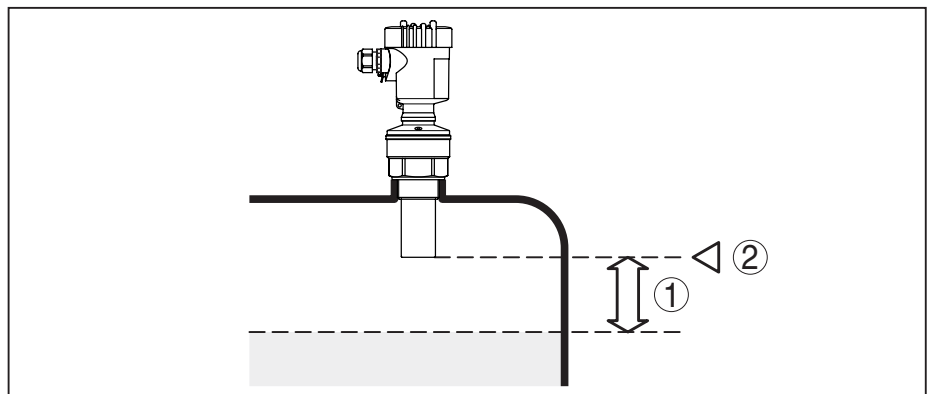

Fig. 3: Minimum distance to the max. level

- 1 Dead zone
- 2 Reference plane



Information:

If the medium reaches the transducer, buildup can form on it and cause faulty measurements later on.

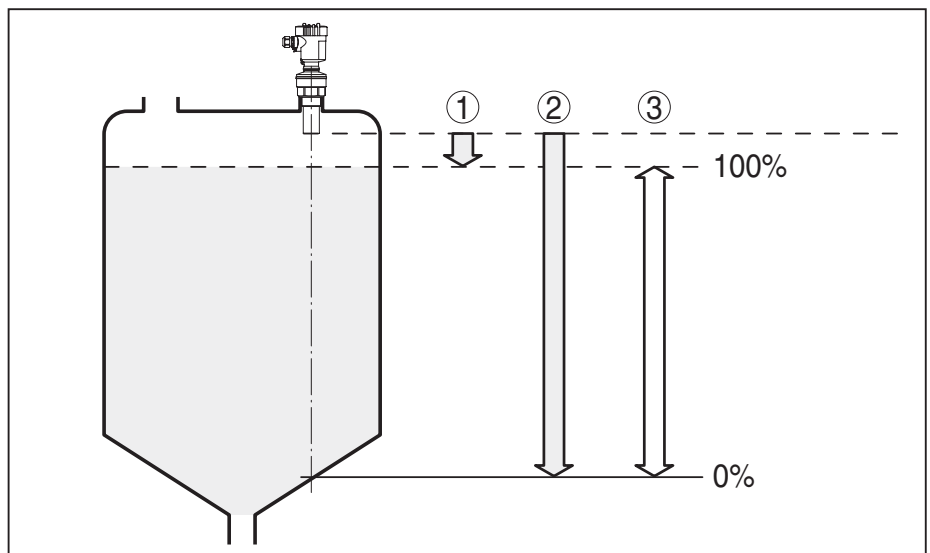

Fig. 4: Measuring range (operating range) and max. measuring distance

- 1 full
- 2 empty (max. measuring distance)
- 3 Measuring range

Pressure/Vacuum

Gauge pressure in the vessel does not influence VEGASON 61. Low pressure or vacuum does, however, damp the ultrasonic pulses. This influences the measuring result, particularly if the level is very low. With pressures under -0.2 bar (-20 kPa) you should use a different measuring principle, e.g. radar or guided radar (TDR).

4.2 Mounting instructions**Screwing in**

Screw VEGASON 61 into the mounting socket with an appropriate spanner applied to the hexagon of the process fitting. Max. torque see chapter "*Technical data*".

**Warning:**

The housing must not be used to screw the instrument in! Applying tightening force can damage internal parts of the housing.

Installation position

When mounting the sensor, keep a distance of at least 200 mm (7.874 in) to the vessel wall. If the sensor is installed in the center of dished or round vessel tops, multiple echoes can arise. These can, however, be suppressed by an appropriate adjustment (see chapter "*Setup*").

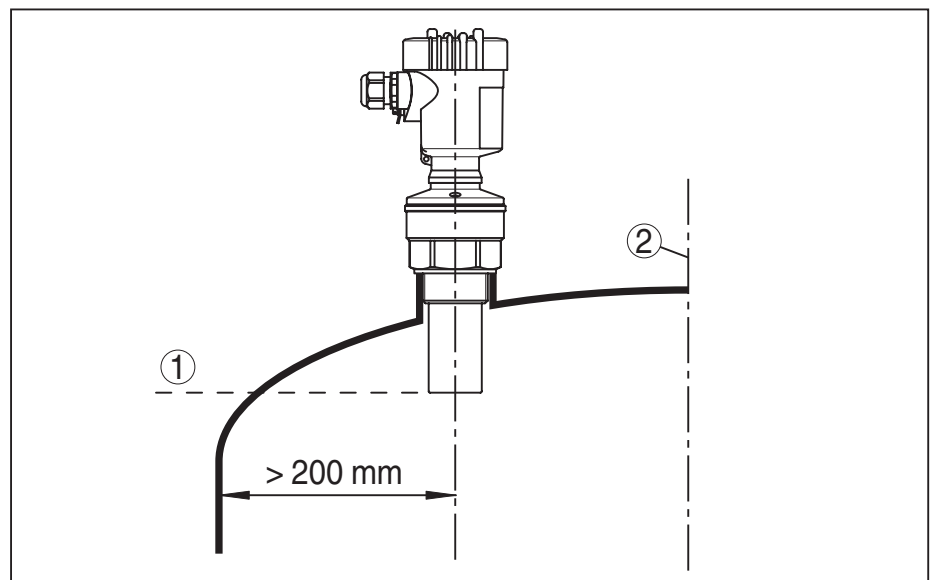

Fig. 5: Mounting on round vessel tops

1 Reference plane

2 Vessel center or symmetry axis

If this distance cannot be maintained, a false signal suppression should be carried out during setup. This applies particularly if buildup on the vessel wall is expected. In such cases, we recommend repeating the false signal suppression at a later date with existing buildup.

In vessels with conical bottom it can be advantageous to mount the sensor in the centre of the vessel, as measurement is then possible down to the bottom.

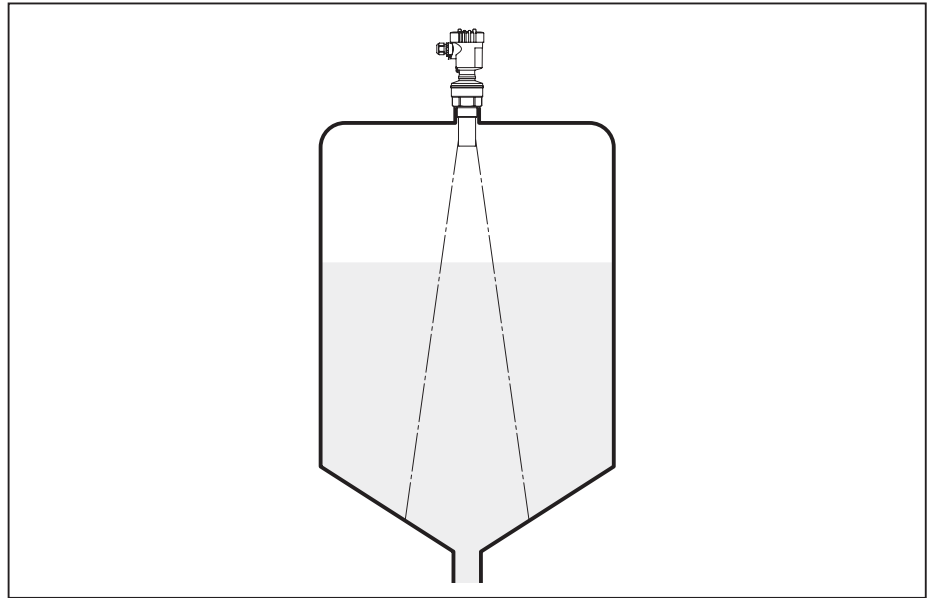

Fig. 6: Vessel with conical bottom

Mounting socket

Socket pieces should be dimensioned so that the lower end of the transducer protrudes at least 10 mm (0.394 in) out of the socket.

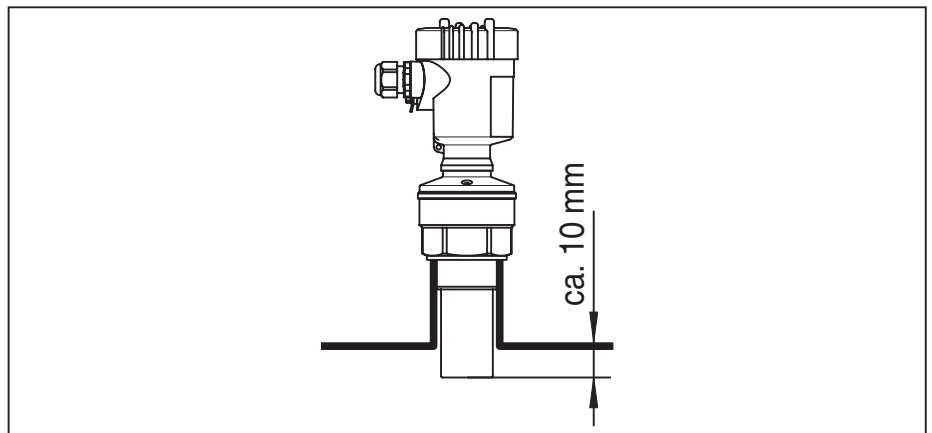

Fig. 7: Recommended socket mounting

If the reflective properties of the medium are good, you can mount VEGASON 61 on sockets which are higher than the length of the transducer. You will find recommended values for socket heights in the following illustration. The socket end should be smooth and burr-free, if possible also rounded. Carry out a false signal suppression.

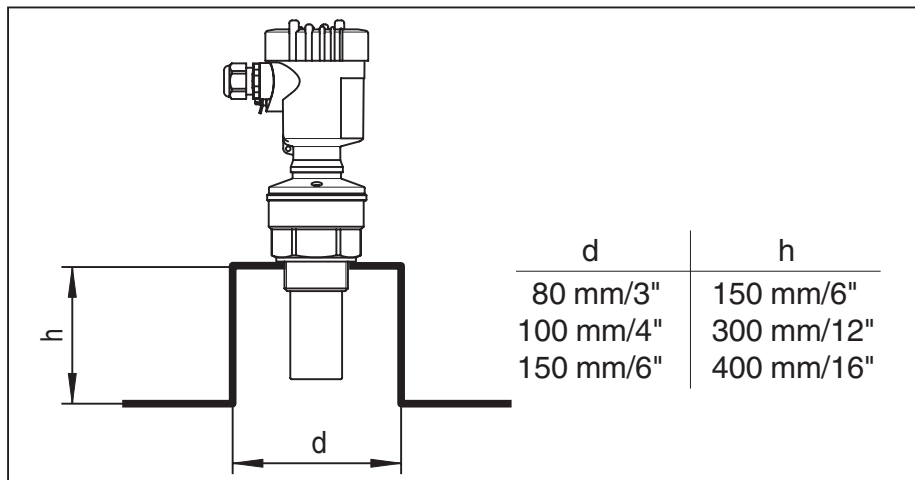

Fig. 8: Deviating socket dimensions

Sensor orientation

In liquids, direct the sensor as perpendicular as possible to the product surface to achieve optimum measurement results.

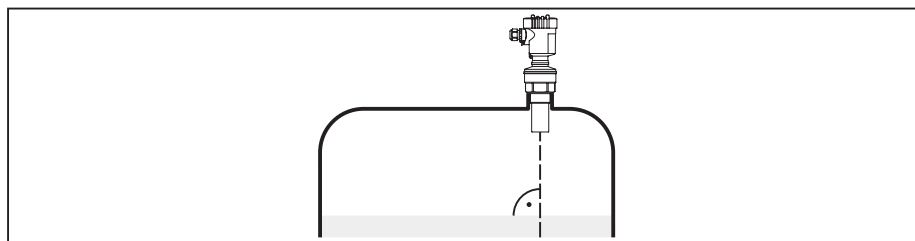

Fig. 9: Alignment in liquids

To reduce the min. distance to the medium, you can also mount VEGASON 61 with a beam deflector. By doing this, it is possible to fill the vessel nearly to maximum. Such an arrangement is suitable primarily for open vessels such as e.g. overflow basins.

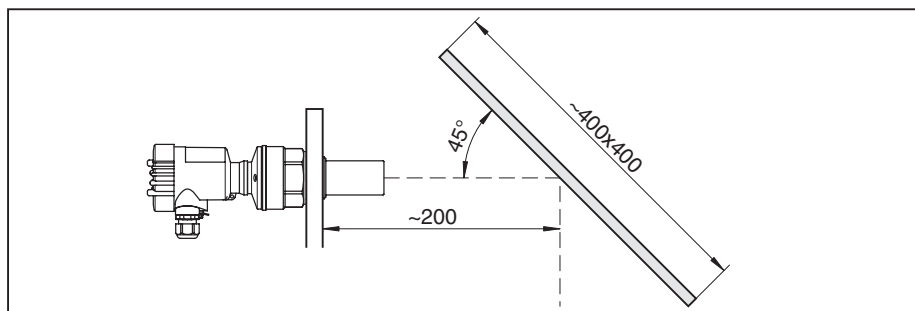

Fig. 10: Beam deflector

Vessel installations

The ultrasonic sensor should be installed at a location where no installations cross the ultrasonic beam.

Vessel installations such as for example, ladders, limit switches, heating spirals, struts etc. can cause false echoes that interfere with the useful echo. Make sure when planning your measuring site that the ultrasonic signals have a "clear view" to the measured product.

In case of existing vessel installations, a false signal suppression should be carried out during setup.

If large vessel installations such as struts or supports cause false echoes, these can be attenuated through supplementary measures. Small, inclined sheet metal or plastic baffles above the installations scatter the ultrasonic signals and avoid direct false echoes.

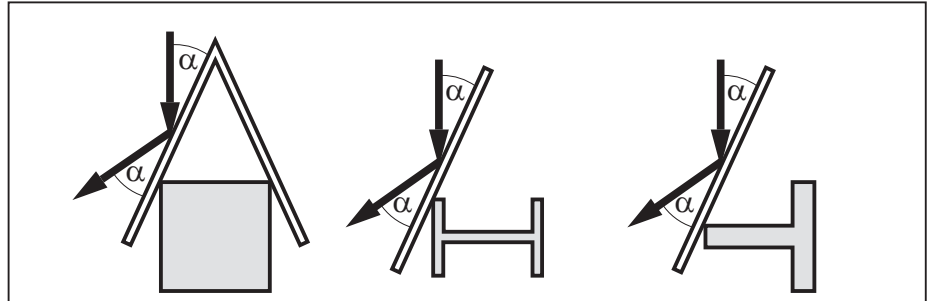

Fig. 11: Cover flat, large-area profiles with deflectors

Agitators

If there are agitators in the vessel, a false signal suppression should be carried out with the agitators in motion. This ensures that the interfering reflections from the agitators are saved with the blades in different positions.

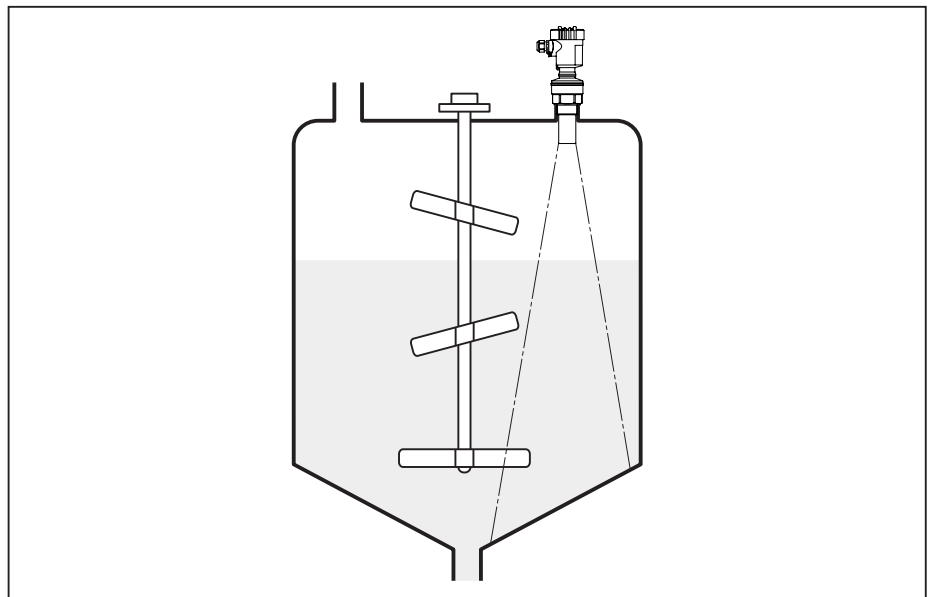

Fig. 12: Agitators

Inflowing medium

Do not mount the instruments in or above the filling stream. Make sure that you detect the product surface, not the inflowing product.

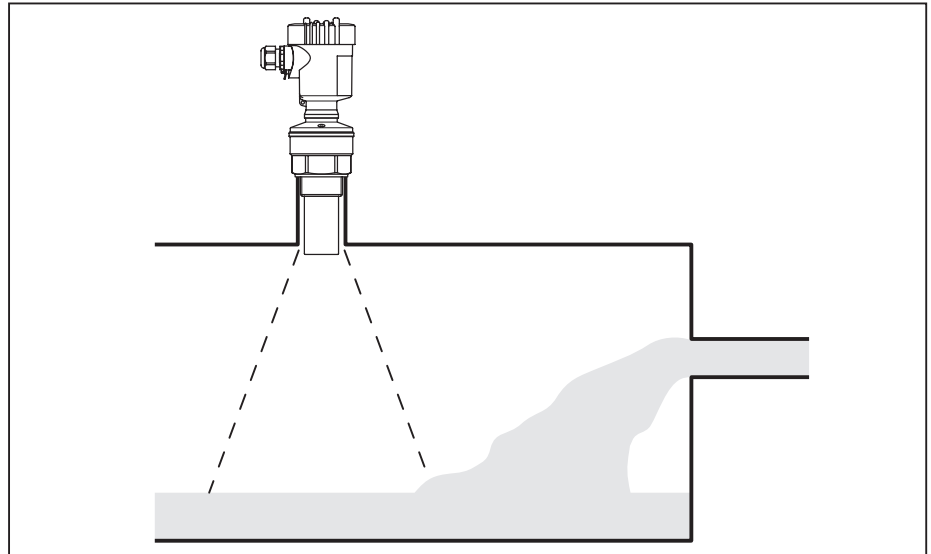

Fig. 13: Inflowing liquid

Foam

Through the action of filling, stirring and other processes in the vessel, dense foams which considerably damp the emitted signals may form on the product surface.

If foams are causing measurement errors, the sensor should be used in a standpipe or, alternatively, the more suitable guided radar sensors (TDR) should be used.

Guided wave radar is unaffected by foam generation and is particularly suitable for such applications.

Air turbulences

If there are strong air currents in the vessel, e.g. due to strong winds in outdoor installations or air turbulence, e.g. by cyclone extraction you should mount VEGASON 61 in a standpipe or use a different measuring principle, e.g. radar or guided radar (TDR).

Standpipe measurement

By using a standpipe (surge or bypass tube), the influence of vessel installations, foam generation and turbulence is excluded.

Standpipes must extend all the way down to the requested min. level, as measurement is only possible within the tube.

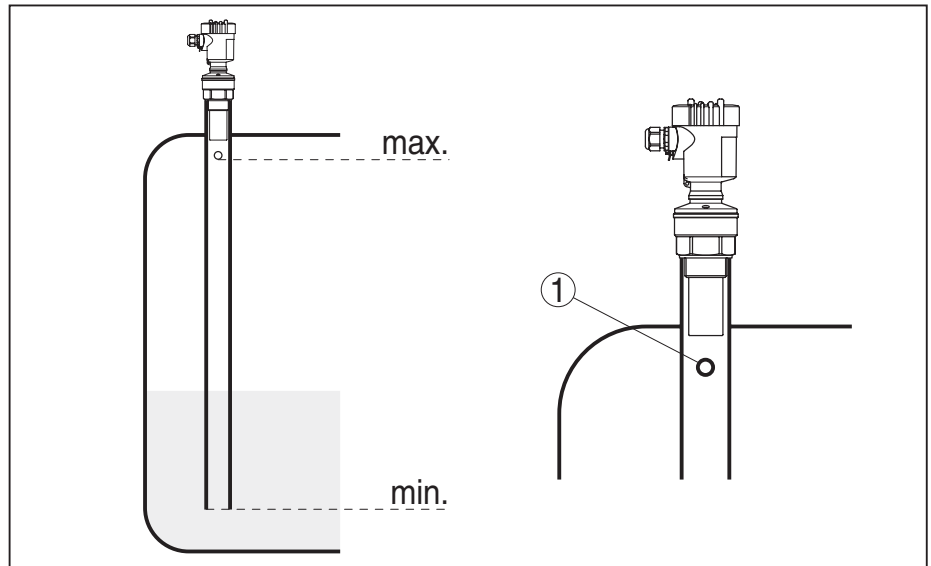

Fig. 14: Standpipe in the tank

1 Vent hole: $\varnothing 5 \dots 10 \text{ mm}$ (0.197 ... 0.394 in)

VEGASON 61 can be used from tube diameters of 40 mm (1.575 in). Avoid large gaps and thick welding joints when connecting the tubes. Generally carry out a false signal suppression.

Measurement in a standpipe is not recommended for extremely adhesive products.

Flow measurement with rectangular overflow

The short examples give you introductory information on flow measurement. Detailed planning information is available from flume manufacturers and in special literature.

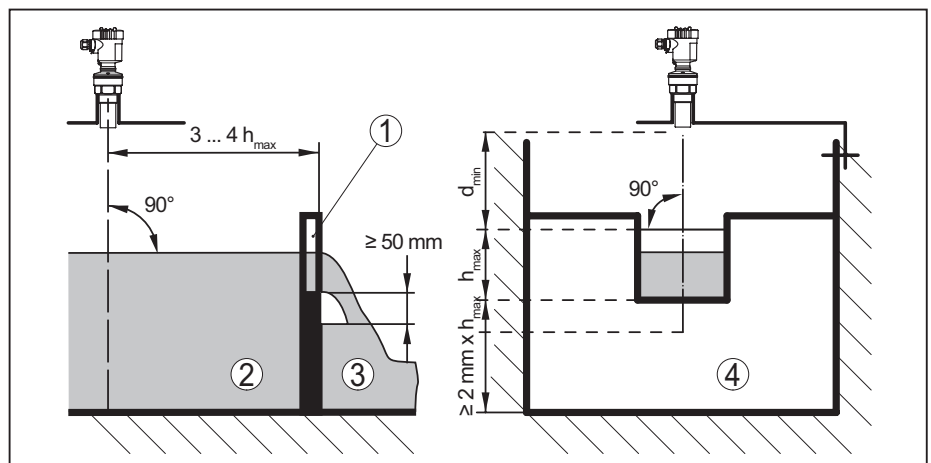

Fig. 15: Flow measurement with rectangular overflow: $d_{min.}$ = min. distance of the sensor (see chapter "Technical data"); $h_{max.}$ = max. filling of the rectangular spillway

- 1 Overflow orifice (side view)
- 2 Headwater
- 3 Tailwater
- 4 Overflow orifice (view from tailwater)

In general, the following points must be observed:

- Install the sensor on the headwater side

- Installation in the centre of the flume and vertical to the liquid surface
- Distance to the overfall orifice
- Distance of orifice opening above ground
- Min. distance of the orifice opening to tailwater
- Min. distance of the sensor to max. storage level

Flow measurement with Khafagi Venturi flume

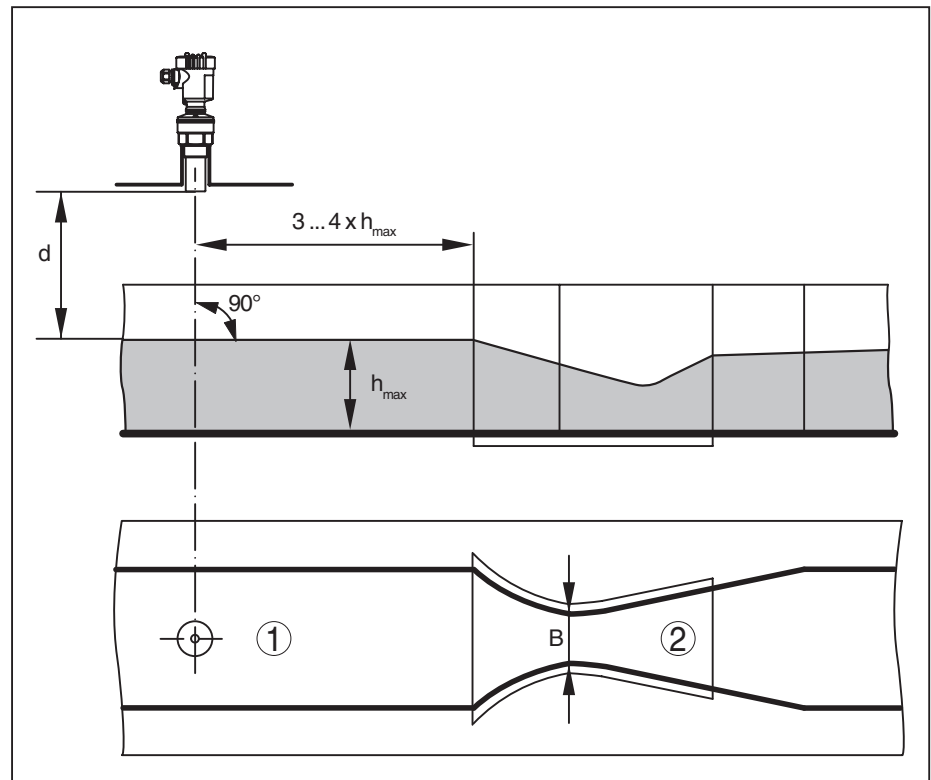

Fig. 16: Flow measurement with Khafagi-Venturi flume: d = Min. distance to sensor; h_{max} = max. filling of the flume; B = tightest constriction in the flume

- 1 Position sensor
- 2 Venturi flume

In general, the following points must be observed:

- Installation of the sensor at the inlet side
- Installation in the centre of the flume and vertical to the liquid surface
- Distance to the Venturi flume
- Min. distance of the sensor to max. storage level

5 Connecting to power supply

5.1 Preparing the connection

Safety instructions

Always keep in mind the following safety instructions:



Warning:

Connect only in the complete absence of line voltage.

- The electrical connection must only be carried out by trained, qualified personnel authorised by the plant operator.
- If overvoltage surges are expected, overvoltage arresters should be installed.

Voltage supply

Power supply and current signal are carried on the same two-wire cable. The operating voltage can differ depending on the instrument version.

The data for power supply are specified in chapter "*Technical data*".

Provide a reliable separation between the supply circuit and the mains circuits according to DIN EN 61140 VDE 0140-1.

Keep in mind the following additional factors that influence the operating voltage:

- Lower output voltage of the power supply unit under nominal load (e.g. with a sensor current of 20.5 mA or 22 mA in case of fault)
- Influence of additional instruments in the circuit (see load values in chapter "*Technical data*")

Connection cable

The instrument is connected with standard two-wire cable without screen. If electromagnetic interference is expected which is above the test values of EN 61326-1 for industrial areas, screened cable should be used.

Make sure that the cable used has the required temperature resistance and fire safety for max. occurring ambient temperature

Use cable with round cross section for instruments with housing and cable gland. To ensure the seal effect of the cable gland (IP protection rating), find out which cable outer diameter the cable gland is suitable for.

Use a cable gland fitting the cable diameter.

We generally recommend the use of screened cable for HART multidrop mode.

Cable gland ½ NPT

On the instrument with cable entry ½ NPT and plastic housing there is a metallic ½" threaded insert moulded into the plastic housing.



Caution:

No grease should be used when screwing the NPT cable gland or steel tube into the threaded insert. Standard grease can contain additives that corrode the connection between threaded insert and housing. This would influence the stability of the connection and the tightness of the housing.

Cable screening and grounding

If screened cable is required, we recommend connecting the cable screen on both ends to ground potential. In the sensor, the screen must be connected directly to the internal ground terminal. The ground terminal on the outside of the housing must be connected to the ground potential (low impedance).



In Ex systems, the grounding is carried out according to the installation regulations.

5.2 Connection procedure

Proceed as follows:

1. Unscrew the housing lid
2. If a display and adjustment module is installed, remove it by turning it to the left
3. Loosen compression nut of the cable gland and remove blind plug
4. Remove approx. 10 cm (4 in) of the cable mantle, strip approx. 1 cm (0.4 in) of insulation from the ends of the individual wires
5. Insert the cable into the sensor through the cable entry
6. Lift the opening levers of the terminals with a screwdriver (see following illustration)
7. Insert the wire ends into the open terminals according to the wiring plan

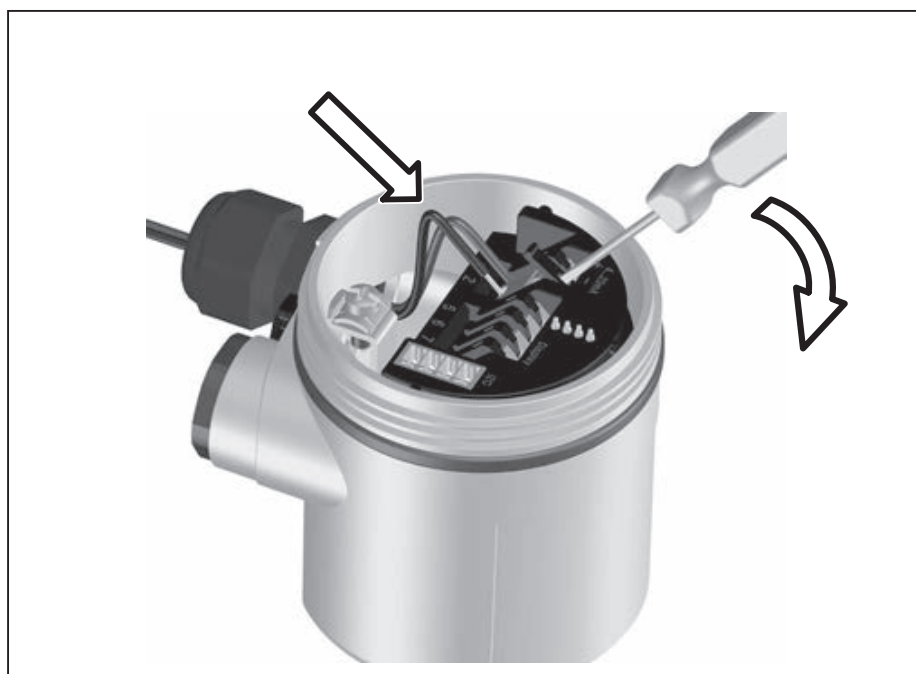

Fig. 17: Connection steps 6 and 7

8. Press down the opening levers of the terminals, you will hear the terminal spring closing
9. Check the hold of the wires in the terminals by lightly pulling on them
10. Connect the screen to the internal ground terminal, connect the external ground terminal to potential equalisation

11. Tighten the compression nut of the cable entry gland. The seal ring must completely encircle the cable
 12. Screw the housing lid back on
- The electrical connection is finished.

5.3 Wiring plan, single chamber housing



The following illustrations apply to the non-Ex as well as to the Ex-ia version.

Housing overview

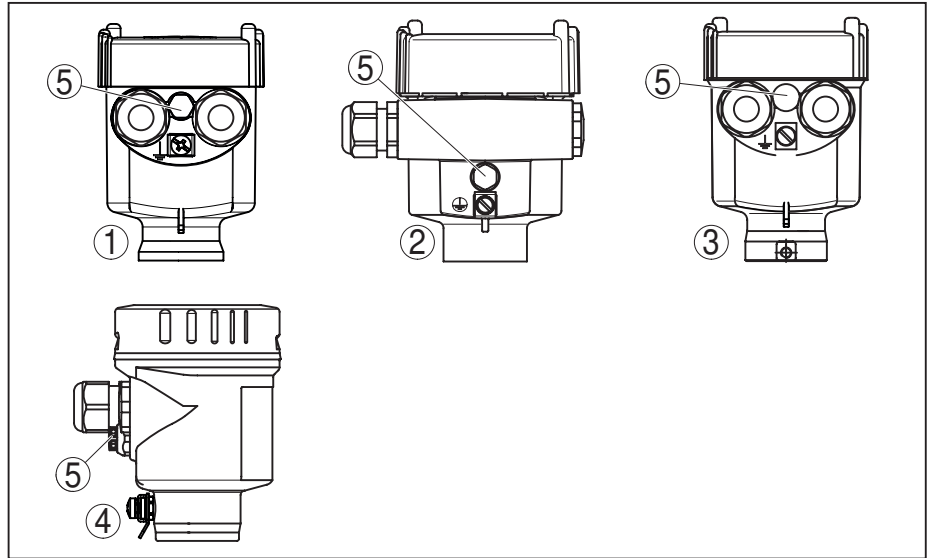

Fig. 18: Material versions, single chamber housing

- 1 Plastic
- 2 Aluminium
- 3 Stainless steel (precision casting)
- 4 Stainless steel (electro-polished)
- 5 Filter element for air pressure compensation of all material versions. Blind plug with version IP 66/IP 68, 1 bar for Aluminium and stainless steel

Electronics and connection compartment

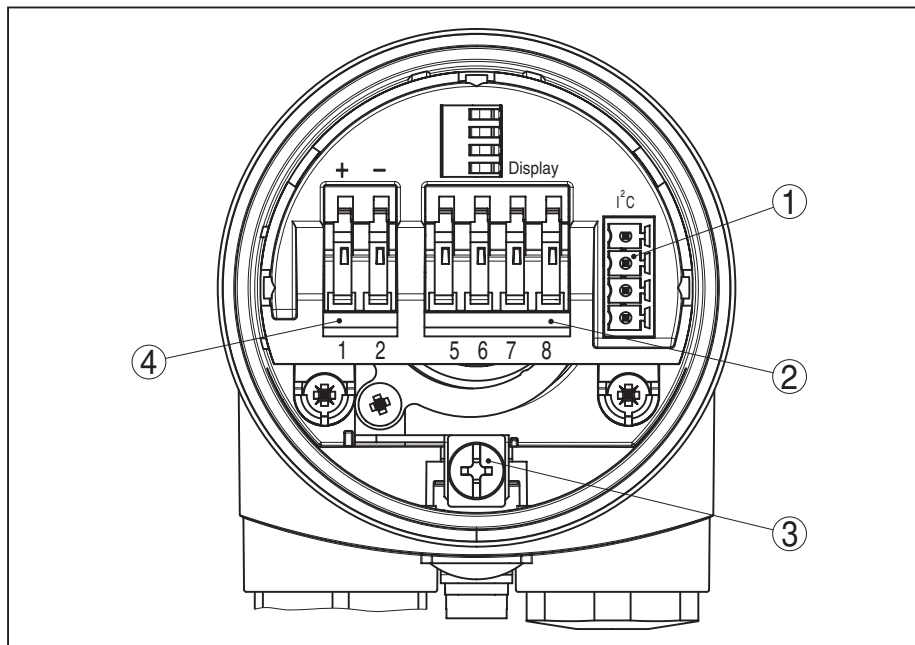

Fig. 19: Electronics and connection compartment - single chamber housing

- 1 Plug connector for VEGACONNECT (I²C interface)
- 2 Spring-loaded terminals for connection of the external indication VEGADIS 81
- 3 Ground terminal for connection of the cable screening
- 4 Spring-loaded terminals for voltage supply

Wiring plan

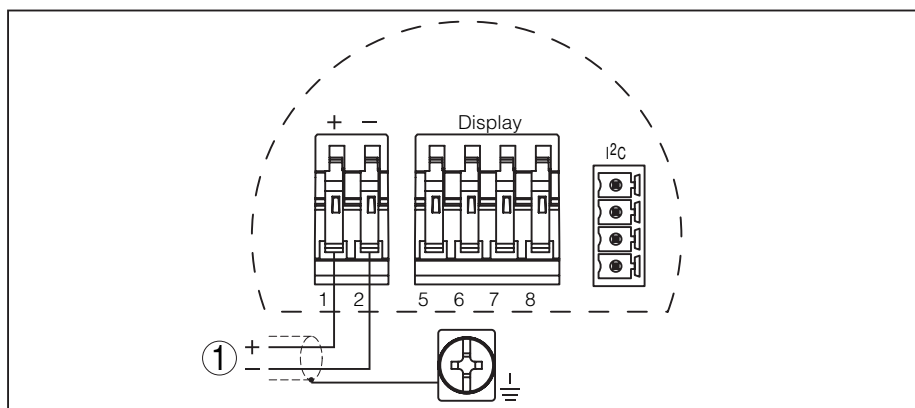

Fig. 20: Wiring plan - single chamber housing

- 1 Voltage supply, signal output

5.4 Wiring plan, double chamber housing



The following illustrations apply to the non-Ex as well as to the Ex-ia version.

Housing overview

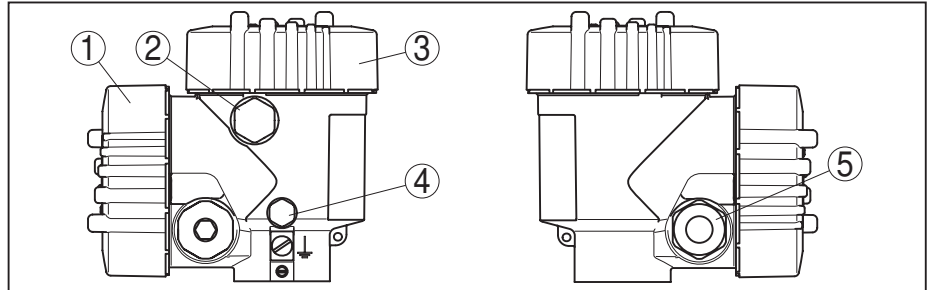

Fig. 21: Double chamber housing

- 1 Housing cover - connection compartment
- 2 Blind plug or plug M12 x 1 for VEGADIS 81 (optional)
- 3 Housing cover - electronics compartment
- 4 Filter element for air pressure compensation
- 5 Cable gland

Electronics compartment

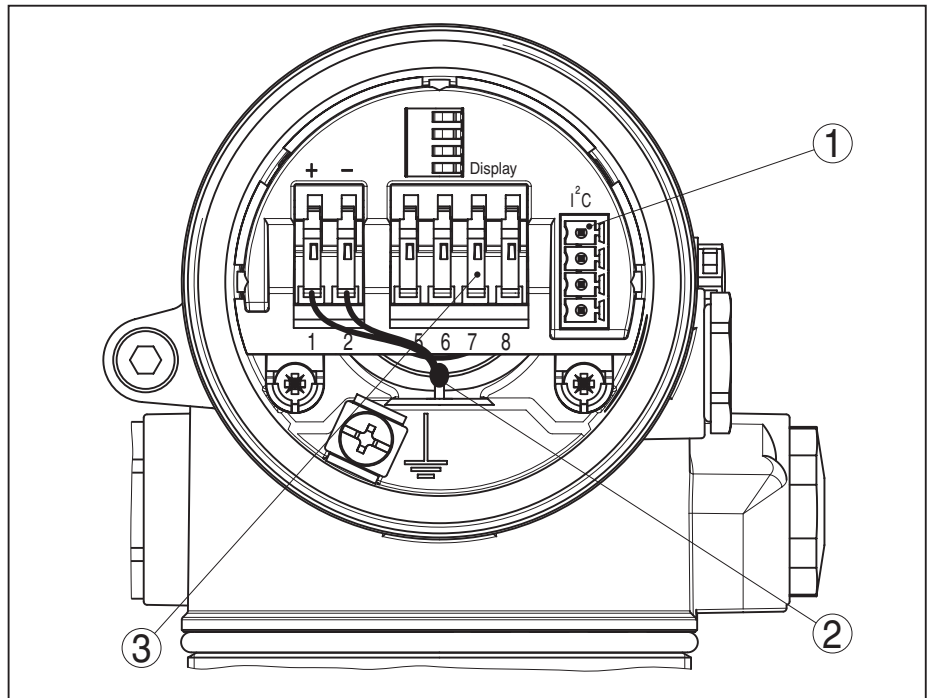

Fig. 22: Electronics compartment - double chamber housing

- 1 Plug connector for VEGACONNECT (I²C interface)
- 2 Internal connection cable to the connection compartment
- 3 Terminals for VEGADIS 81

Connection compartment

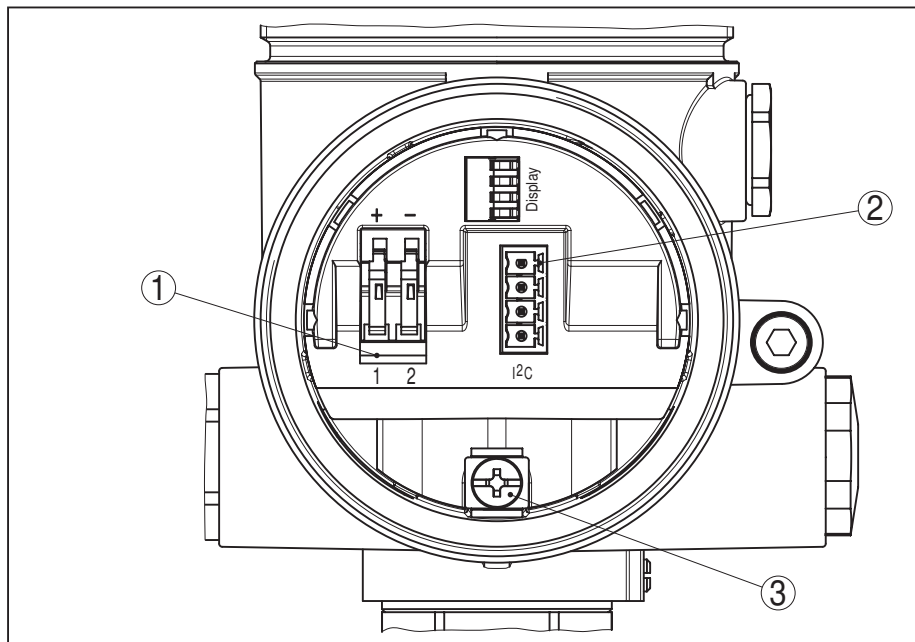

Fig. 23: Connection compartment - double chamber housing

- 1 Spring-loaded terminals for voltage supply
- 2 Plug connector for VEGACONNECT (I²C interface)
- 3 Ground terminal for connection of the cable screening

Wiring plan

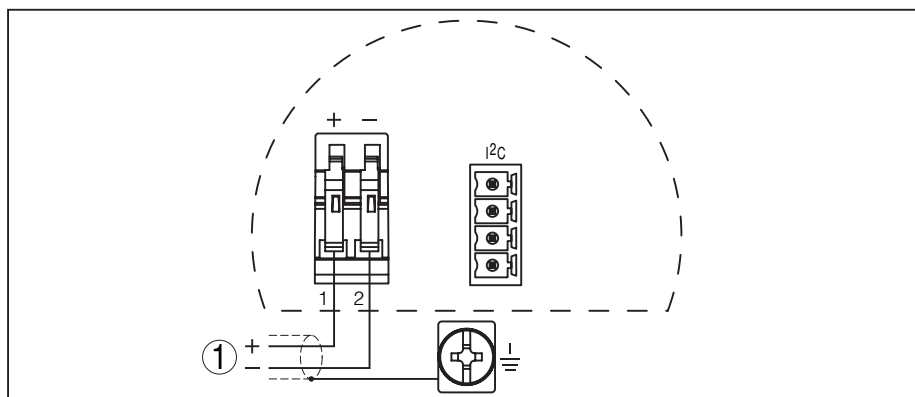

Fig. 24: Wiring plan - double chamber housing

- 1 Voltage supply, signal output

5.5 Wiring plan - version IP 66/IP 68 (1 bar)

Wire assignment, connection cable

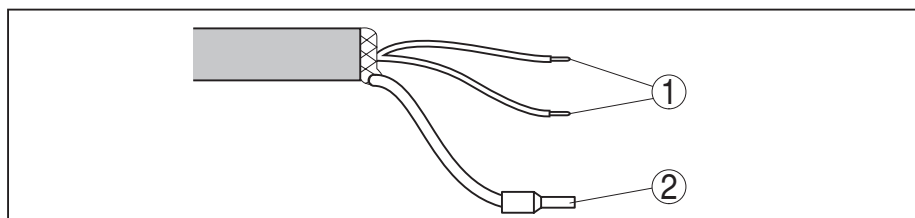

Fig. 25: Wire assignment, connection cable

- 1 Brown (+) and blue (-) to power supply or to the processing system
- 2 Shielding

Switch-on phase**5.6 Switch-on phase**

After connecting VEGASON 61 to power supply or after a voltage recurrence, the instrument carries out a self-check for approx. 30 seconds:

- Internal check of the electronics
- Indication of the instrument type, the firmware as well as the sensor TAGs (sensor designation)
- Output signal jumps briefly (approx. 10 seconds) to the set fault current

Then the corresponding current is output to the cable (the value corresponds to the actual level as well as the settings already carried out, e.g. factory setting).

6 Set up with the display and adjustment module PLICSCOM

Mount/dismount display and adjustment module

6.1 Insert display and adjustment module

The display and adjustment module can be inserted into the sensor and removed again at any time. It is not necessary to interrupt the voltage supply.

Proceed as follows:

1. Unscrew the housing lid
2. Place the display and adjustment module in the desired position on the electronics (you can choose any one of four different positions - each displaced by 90°)
3. Press the display and adjustment module onto the electronics and turn it to the right until it snaps in
4. Screw housing lid with inspection window tightly back on

Disassembly is carried out in reverse order.

The display and adjustment module is powered by the sensor, an additional connection is not necessary.



Fig. 26: Insert display and adjustment module



Note:

If you intend to retrofit the instrument with a display and adjustment module for continuous measured value indication, a higher lid with an inspection glass is required.

6.2 Adjustment system

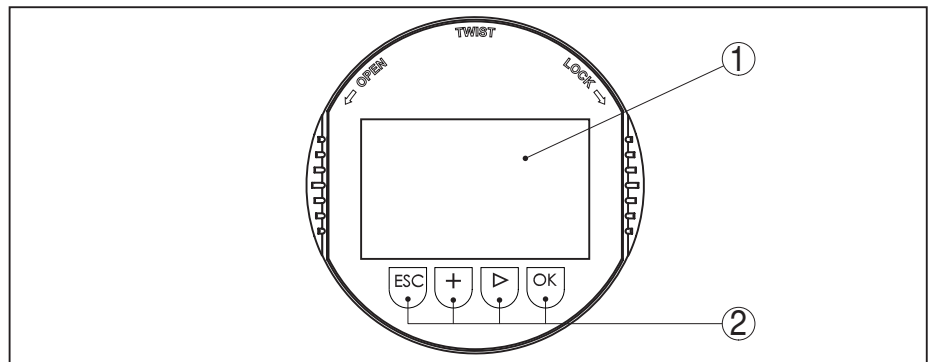

Fig. 27: Display and adjustment elements

- 1 LC display
- 2 Adjustment keys

Key functions

- **[OK]** key:
 - Move to the menu overview
 - Confirm selected menu
 - Edit parameter
 - Save value
- **[->]** key:
 - Change measured value presentation
 - Select list entry
 - Select menu items in the quick setup menu
 - Select editing position
- **[+]** key:
 - Change value of the parameter
- **[ESC]** key:
 - Interrupt input
 - Jump to next higher menu

Operating system - Keys direct

The instrument is operated via the four keys of the display and adjustment module. The individual menu items are shown on the LC display. You can find the function of the individual keys in the previous illustration.

Adjustment system - keys via magnetic pen

With the Bluetooth version of the display and adjustment module you can also adjust the instrument with the magnetic pen. The pen operates the four keys of the display and adjustment module right through the closed lid (with inspection window) of the sensor housing.

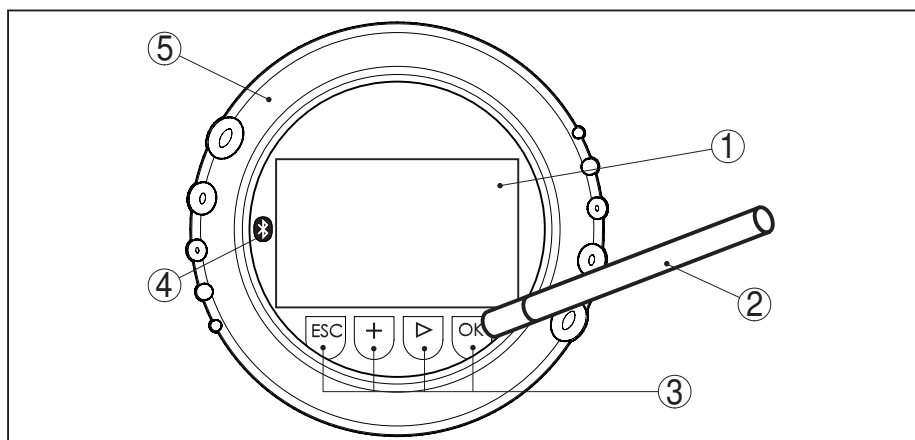

Fig. 28: Display and adjustment elements - with adjustment via magnetic pen

- 1 LC display
- 2 Magnetic pen
- 3 Adjustment keys
- 4 Bluetooth symbol
- 5 Lid with inspection window

Time functions

When the **[+]** and **[->]** keys are pressed quickly, the edited value, or the cursor, changes one value or position at a time. If the key is pressed longer than 1 s, the value or position changes continuously.

When the **[OK]** and **[ESC]** keys are pressed simultaneously for more than 5 s, the display returns to the main menu. The menu language is then switched over to "English".

Approx. 60 minutes after the last pressing of a key, an automatic reset to measured value indication is triggered. Any values not confirmed with **[OK]** will not be saved.

6.3 Setup steps

Address setting HART multidrop

In HART-Multidrop mode (several sensors on one input) the address must be set before continuing with the parameter adjustment. You will find a detailed description in the operating instructions manual "Display and adjustment module" or in the online help of PACTware or DTM.

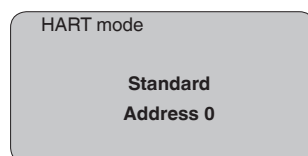

Parameter adjustment

The sensor measures the distance from the sensor to the product surface. For indication of the real level, an allocation of the measured distance to the percentage height must be carried out.

The actual level is then calculated on the basis of these entered values. At the same time, the operating range of the sensor is limited from maximum range to the requested range.

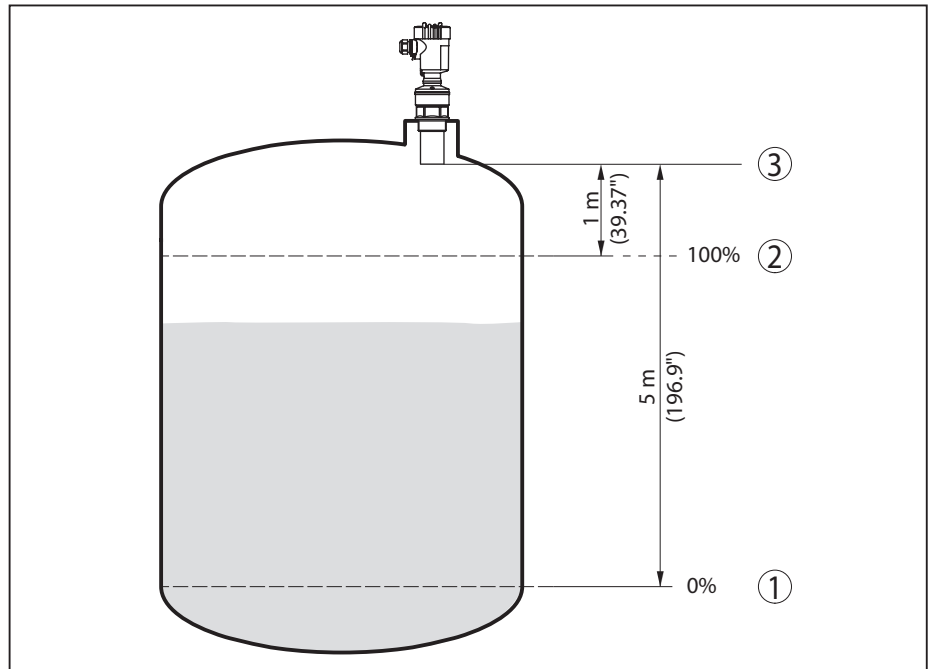

Fig. 29: Parameterisation example, Min./max. adjustment

- 1 Min. level = max. measuring distance
- 2 Max. level = min. measuring distance
- 3 Reference plane

The actual product level during this adjustment is not important, because the min./max. adjustment is always carried out without changing the product level. These settings can be made ahead of time without the instrument having to be installed.

Basic adjustment - Min. adjustment

Proceed as follows:

1. Move from the measured value display to the main menu by pushing **[OK]**.

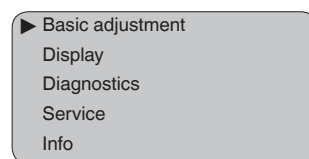

2. Select the menu item "Basic adjustment" with **[->]** and confirm with **[OK]**. Now the menu item "Min. adjustment" is displayed.

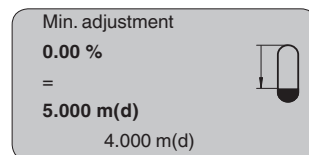

3. Prepare the % value for editing with **[OK]** and set the cursor to the requested position with **[->]**. Set the requested percentage value with **[+]** and save with **[OK]**. The cursor jumps now to the distance value.
4. Enter the distance value in m for empty vessel (e.g. distance from the sensor to the vessel bottom) corresponding to the percentage value.

5. Save the settings with **[OK]** and move to "Max. adjustment" with **[->]**.

Basic adjustment - Max. adjustment

Proceed as follows:

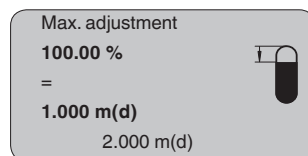

1. Prepare the % value for editing with **[OK]** and set the cursor to the requested position with **[->]**. Set the requested percentage value with **[+]** and save with **[OK]**. The cursor jumps now to the distance value.
2. Enter the appropriate distance value in m (corresponding to the percentage value) for the full vessel. Keep in mind that the max. level must lie below the dead band.
3. Save the settings with **[OK]** and move to "Medium selection" with **[->]**.

Basic adjustment - Medium

Each product has different reflective properties. In addition, there are various interfering factors which have to be taken into account: agitated product surfaces and foam generation (with liquids); dust generation, material cones and echoes from the vessel wall (with solids). To adapt the sensor to these different conditions, you should first select "*Liquid*" or "*Solid*".

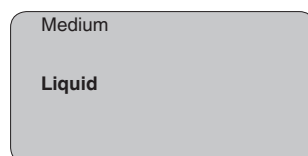

With solids, you can also choose between "*Powder/Dust*", "*Granular/Pellets*" or "*Ballast/Pebbels*".

Through this additional selection, the sensor is adapted perfectly to the product and measurement reliability, particularly in products with poor reflective properties, is considerably increased.

Enter the requested parameters via the appropriate keys, save your settings and jump to the next menu item with the **[->]** key.

Basic adjustment - Vessel form

Apart from the medium, the vessel shape can also influence the measurement. To adapt the sensor to these measuring conditions, this menu item offers different options depending on whether liquid or bulk solid is selected. With "*Liquids*" these are "*Storage tank*", "*Stilling tube*", "*Open vessel*" or "*Stirred vessel*", with "*Solid*", "*Silo*" or "*Bunker*".

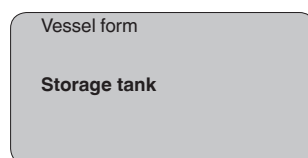

Enter the requested parameters via the appropriate keys, save your settings and jump to the next menu item with the **[->]** key.

Basic adjustment - Damping

To suppress fluctuations in the measured value display, e. g. caused by an agitated product surface, a damping can be set. This time can be between 0 and 999 seconds. Keep in mind that the reaction time of the entire measurement will then be longer and the sensor will react to measured value changes with a delay. In general, a period of a few seconds is sufficient to smooth the measured value display.

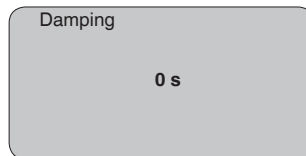

Enter the requested parameters via the appropriate keys, save your settings and jump to the next menu item with the **[->]** key.

Basic adjustment - Linearization curve

A linearisation is necessary for all vessels in which the vessel volume does not increase linearly with the level - e.g. in a horizontal cylindrical or spherical tank - and the indication or output of the volume is required. Corresponding linearisation curves are preprogrammed for these vessels. They represent the correlation between the level percentage and vessel volume. By activating the appropriate curve, the volume percentage of the vessel is displayed correctly. If the volume should not be displayed in percent but e.g. in l or kg, a scaling can be also set in the menu item "Display".

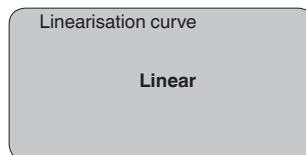

Enter the requested parameters via the appropriate keys, save your settings and jump to the next menu item with the **[->]** key.

Basic adjustment - Sensor TAG

In this menu item you can enter an unambiguous designation for the sensor, e.g. the measurement loop name or the tank or product designation. In digital systems and in the documentation of larger plants, a singular designation should be entered for exact identification of individual measuring points.

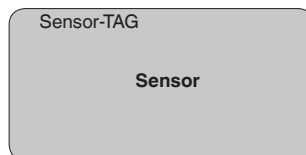

With this menu item, the Basic adjustment is finished and you can now jump to the main menu with the **[ESC]** key.

Display - Indicated value

In the menu item "Display" you can define how the measured value should be presented on the display.

The following indication values are available:

- Height
- Distance
- Current
- Scaled
- Percent

- Lin. percent

The selection "scaled" opens the menu items "Display unit" and "Scaling". In "Display unit" there are the following options:

- Height
- Ground
- Flow
- Volume
- Without unit

Depending on selection, the different units are in turn available.

In the menu item "Scaling", the requested numerical value with decimal point is entered for 0 % and 100 % of the measured value.

There is the following relationship between the indication value in the menu "Display" and the adjustment unit in the menu "Device settings":

- Indication value "Distance": Presentation of the measured value in the selected adjustment unit, e.g. m(d).

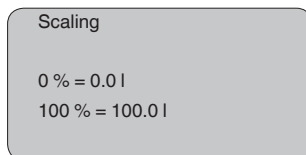
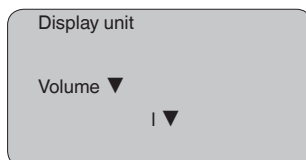

Display - Backlight

A background lighting integrated by default can be adjusted via the adjustment menu. The function depends on the height of the supply voltage. See "Technical data/Voltage supply".

To maintain the function of the device, the lighting is temporarily switched off if the power supply is insufficient.



In the default setting, the lightning is switched off.

Diagnosis - Peak value

The respective min. and max. measured values are saved in the sensor. The values are displayed in the menu item "Peak values".

- Min. and max. distance in m(d)
- Min. and max. temperature

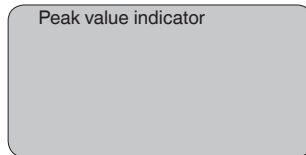

Diagnosis - Measurement reliability

When non-contact level sensors are used, the measurement can be influenced by the respective process conditions. In this menu item, the measurement reliability of the level echo is displayed as a dB value. Measurement reliability equals signal strength minus noise. The higher the value, the more reliable the measurement. A well functioning measurement normally has a value > 10 dB.

Diagnostics - Device status

The instrument status is displayed in this menu item. If no failure is detected by the sensor, "OK" will be displayed. If a failure is detected, there will be a sensor-specific flashing fault signal, for example "E013". The failure is also displayed in clear text, for example "No measured value available".



Information:

The fault message as well as the clear text indication are also carried out in the measured value display.

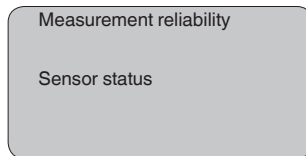

Diagnosis - Curve selection

With ultrasonic sensors, the "**Echo curve**" represents the signal strength of the echoes over the measuring range. The unit of signal strength is "dB". The signal strength enables the judgement of the quality of the measurement.

The "**False echo curve**" displays the saved false echoes (see menu "Service") of the empty vessel as signal strength in "dB" over the measuring range.

Up to 3000 measured values are recorded (depending on the sensor) when starting a "**Trend curve**". Then the values can be displayed on a time axis. The oldest measured values are always deleted.

In the menu item "Choose curve", the respective curve is selected.

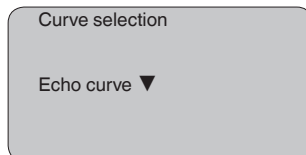

Information:

The trend recording is not activated when being shipped. It must be started by the user via the menu item "Start trend curve".

Diagnosis - Curve presentation

A comparison of the echo curve and the false echo curve allows a more detailed evaluation of measurement reliability. The selected curve is updated continuously. With the [OK] key, a submenu with zoom functions is opened.

The following functions are available with "**Echo and false echo curve**":

- "X-Zoom": Zoom function for the meas. distance
- "Y-Zoom": 1, 2, 5 and 10x signal magnification in "dB"
- "Unzoom": Reset the presentation to the nominal measuring range without magnification

In the menu item "**Trend curve**" the following are available:

- "X-Zoom": Resolution
 - 1 minute
 - 1 hour
 - 1 day
- "Stop/Start": Interrupt a recording or start a new recording
- "Unzoom": Reset the resolution to minutes

As default setting, the recording pattern has 1 minute. With the adjustment software PACTware, this pattern can be also set to 1 hour or 1 day.

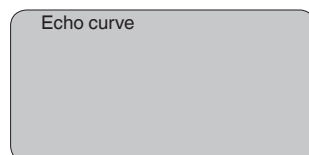

Service - False signal suppression

High sockets or vessel installations, such as e. g. struts or agitators as well as buildup and weld joints on the vessel walls, cause interfering reflections which can impair the measurement. A false echo storage detects and marks these false echoes, so that they are no longer taken into account for the level measurement. A false echo memory should be created with low level so that all potential interfering reflections can be detected.

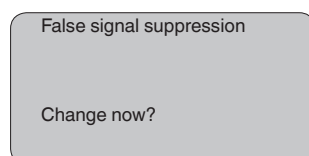

Proceed as follows:

1. Move from the measured value display to the main menu by pushing **[OK]**.
2. Select the menu item "*Service*" with **[->]** and confirm with **[OK]**. Now the menu item "*False signal suppression*" is displayed.
3. Confirm "*False signal suppression - Change now*" with **[OK]** and select in the below menu "*Create new*". Enter the actual distance from the sensor to the product surface. All false signals in this area are detected by the sensor and saved after confirming with **[OK]**.



Note:

Check the distance to the product surface, because if an incorrect (too large) value is entered, the existing level will be saved as a false signal. The level would then no longer be detectable in this area.

Service - Extended setting

The menu item "*Extended setting*" offers the possibility to optimise VEGASON 61 for applications in which the level changes very quickly. To do this, select the function "*Quick level change > 1 m/min.*".

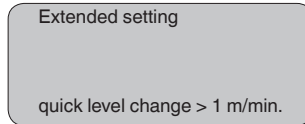

Note:

Since with the function "*Quick level change > 1 m/min.*" the generation of an average value of the signal processing is considerably reduced, false reflections by agitators or vessel installations can cause measured value fluctuations. A false signal suppression is thus recommended.

Service - Current output

In the menu item "*Current output*" you determine the behaviour of the current output during operation and in case of failure. The following options are available:

Current output

Characteristics	4 ... 20 mA 20 ... 4 mA
Failure mode ¹⁾	Hold value 20.5 mA 22 mA < 3.6 mA
Min. current ²⁾	3.8 mA 4 mA
Max. current ³⁾	20 mA 20.5 mA

The values in bold font represent the data of the factory setting.

In HART multidrop mode, the current is constantly 4 mA. This value does not change even in case of failure.

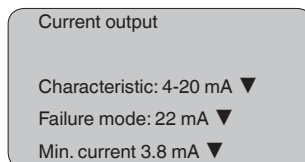

Service - Simulation

In this menu item you simulate a user-defined level or pressure value via the current output. This allows you to test the signal path, e.g. through connected indicating instruments or the input card of the control system.

The following simulation variables are available:

- 1) Value of the current output in case of failure, e.g. if no valid measured value is delivered.
- 2) This value is not underrun during operation.
- 3) This value is not exceeded during operation.

- Percent
- Current
- Pressure (with pressure transmitters)
- Distance (with radar and guided radar (GWR))

With Profibus PA sensors, the selection of the simulated value is made via the "Channel" in the menu "*Basic adjustments*".

How to start the simulation:

1. Push **[OK]**
2. Select the requested simulation variable with **[->]** and confirm with **[OK]**.
3. Set the requested numerical value with **[+]** and **[->]**.
4. Push **[OK]**

The simulation is now running, with 4 ... 20 mA/HART a current is output and with Profibus PA or Foundation Fieldbus a digital value.

How to interrupt the simulation:

→ Push **[ESC]**



Information:

The simulation is automatically terminated 10 minutes after the last pressing of a key.

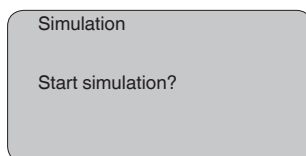

Service - Reset

If the function "*Reset*" is carried out, the sensor resets the values of the following menu items to the reset values (see table):⁴⁾

Function	Reset value
Sensor address	126
Max. adjustment	0 m(d)
Min. adjustment	Meas. range end in m(d) ⁵⁾
Medium	Liquid
Vessel form	not known
Damping	0 s
Linearisation	Linear
Sensor-TAG	Sensor
Displayed value	Distance
Current output - characteristics	4 ... 20 mA
Current output - max. current	20 mA
Current output - min. current	4 mA
Current output - failure	< 3.6 mA

⁴⁾ Sensor-specific basic adjustment.

⁵⁾ Depending on the sensor type, see chapter "Technical data".

Function	Reset value
Unit of measurement	m(d)

The values of the following menu items are *not* reset to the reset values (see table) with "**Reset**":

Function	Reset value
Backlight	No reset
Language	No reset
HART mode	No reset

Default setting

Like basic adjustment, but in addition, special parameters are reset to default values.⁶⁾

Peak value indicator

The min. and max. distance and temperature values are reset to the actual value.

Service - Adjustment unit In this menu item you select the internal arithmetic unit of the sensor.

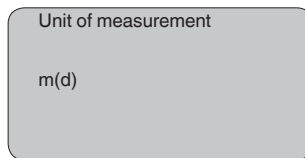

Service - Language The sensor is already set to the ordered national language. In this menu item you can change the language. The following languages are available as of software version 3.50:

- Deutsch
- English
- Français
- Español
- Pycckuu
- Italiano
- Netherlands
- Japanese
- Chinese

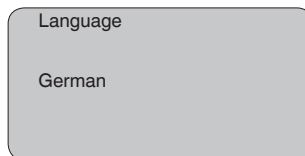

Service - SIL The functional safety is already activated Ex factory for instruments with SIL qualification. For instruments Ex factory without SIL qualification, the functional safety must be activated by the user for applications according to SIL via the indicating and adjustment module. The SIL factory setting cannot be deactivated by the user.

⁶⁾ Special parameters are parameters which are set customer-specifically on the service level with the adjustment software PACTware.

The activation of SIL has the following impact:

- In the menu item "*Failure mode*" under "*Current output*", the parameters "*Hold value*" and "*20.5 mA*" are blocked
- In the menu item "*HART mode*", the function "*Multidrop*" is blocked



Note:

For such applications, it is absolutely necessary to take note of "*Safety Manual*".

Service - HART mode

HART offers standard and multidrop mode.

The mode "standard" with the fixed address 0 means outputting the measured value as a 4 ... 20 mA signal.

In Multidrop mode, up to 15 sensors can be operated on one two-wire cable. An address between 1 and 15 must be assigned to each sensor.⁷⁾

In this menu item you determine the HART mode and enter the address for multidrop.

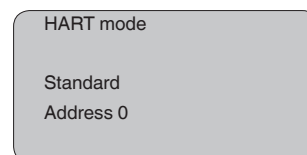

The default setting is standard with address 0.

Service - Copy sensor data

This function enables reading out parameter adjustment data as well as writing parameter adjustment data into the sensor via the display and adjustment module. A description of the function is available in the operating instructions manual "*Display and adjustment module*".

The following data are read out or written with this function:

- Measured value presentation
- Adjustment
- Medium
- Vessel form
- Damping
- Linearisation curve
- Sensor-TAG
- Displayed value
- Display unit
- Scaling
- Current output
- Unit of measurement
- Language

The following safety-relevant data are **not** read out or written:

- HART mode
- PIN

⁷⁾ The 4 ... 20 mA signal of the sensor is switched off. The sensor uses a constant current of 4 mA. The measuring signal is transmitted exclusively as a digital HART signal.

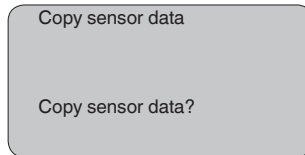

Service - PIN

In this menu item, the PIN is activated/deactivated permanently. Entering a 4-digit PIN protects the sensor data against unauthorized access and unintentional modifications. If the PIN is activated permanently, it can be deactivated temporarily (i.e. for approx. 60 min.) in any menu item. The instrument is delivered with the PIN set to 0000.

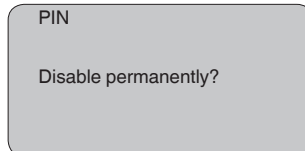

Only the following functions are permitted with activated PIN:

- Select menu items and show data
- Read data from the sensor into the display and adjustment module

Info

In this menu item the most important sensor information can be displayed:

- Instrument type
- Serial number: 8-digit number, e.g. 12345678

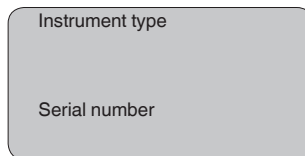

- Date of manufacture: Date of the factory calibration
- Software version: Edition of the sensor software

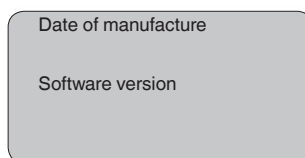

- Date of last change using PC: Date of the last change of sensor parameters via PC

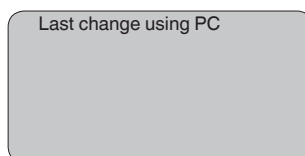

- Sensor details, e.g. approval, process fitting, seal, measuring cell, measuring range, electronics, housing, cable entry, plug, cable length etc.

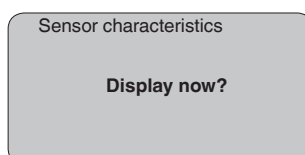

6.4 Menu schematic



Information: Depending on the version and application, the highlighted menu windows may not always be available.

Basic adjustment

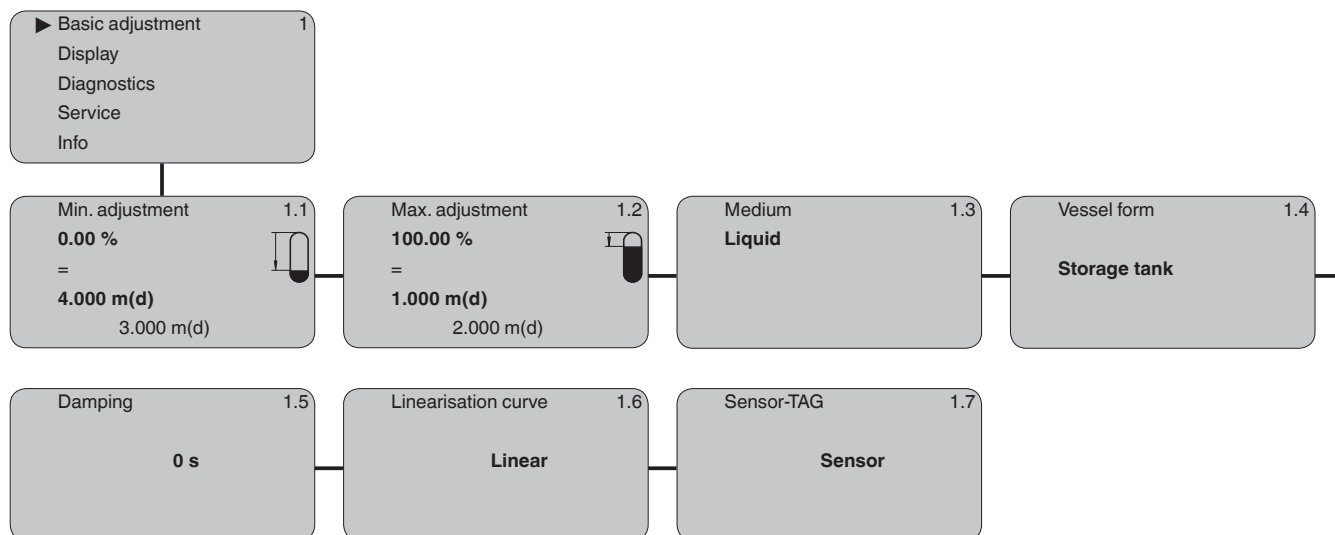

Display

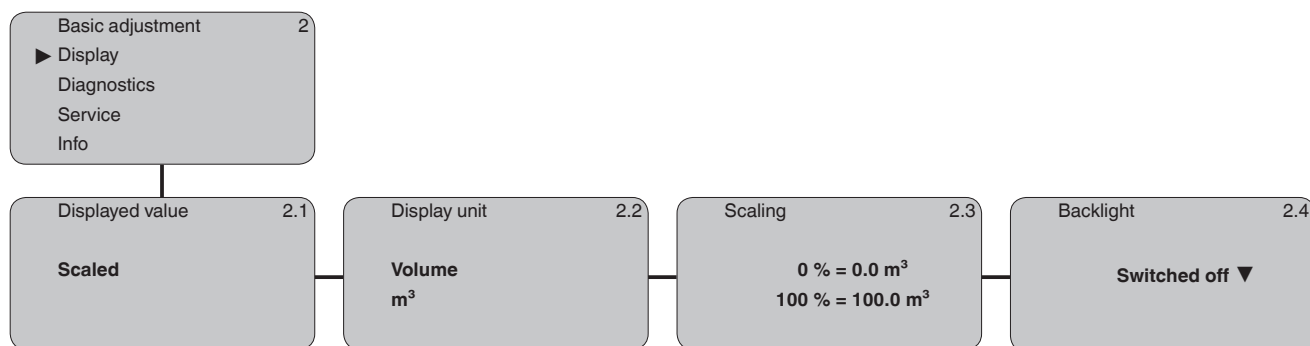

Diagnostics

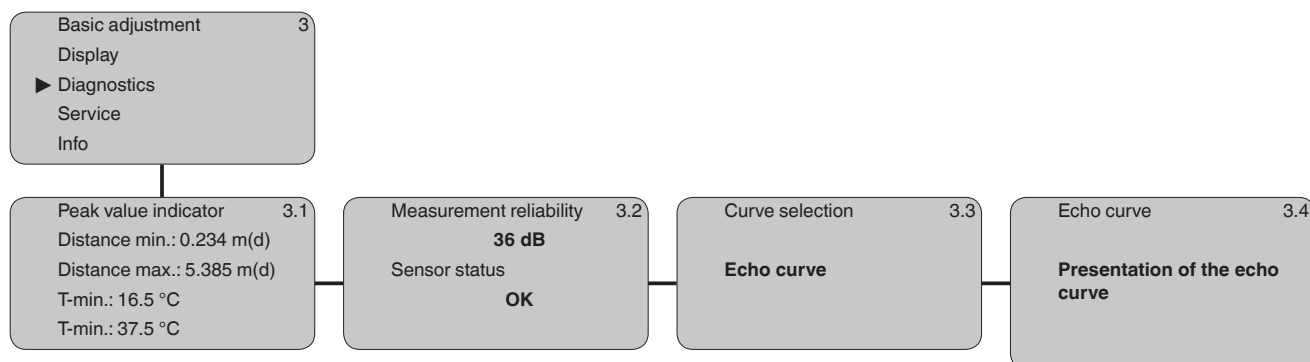

Service

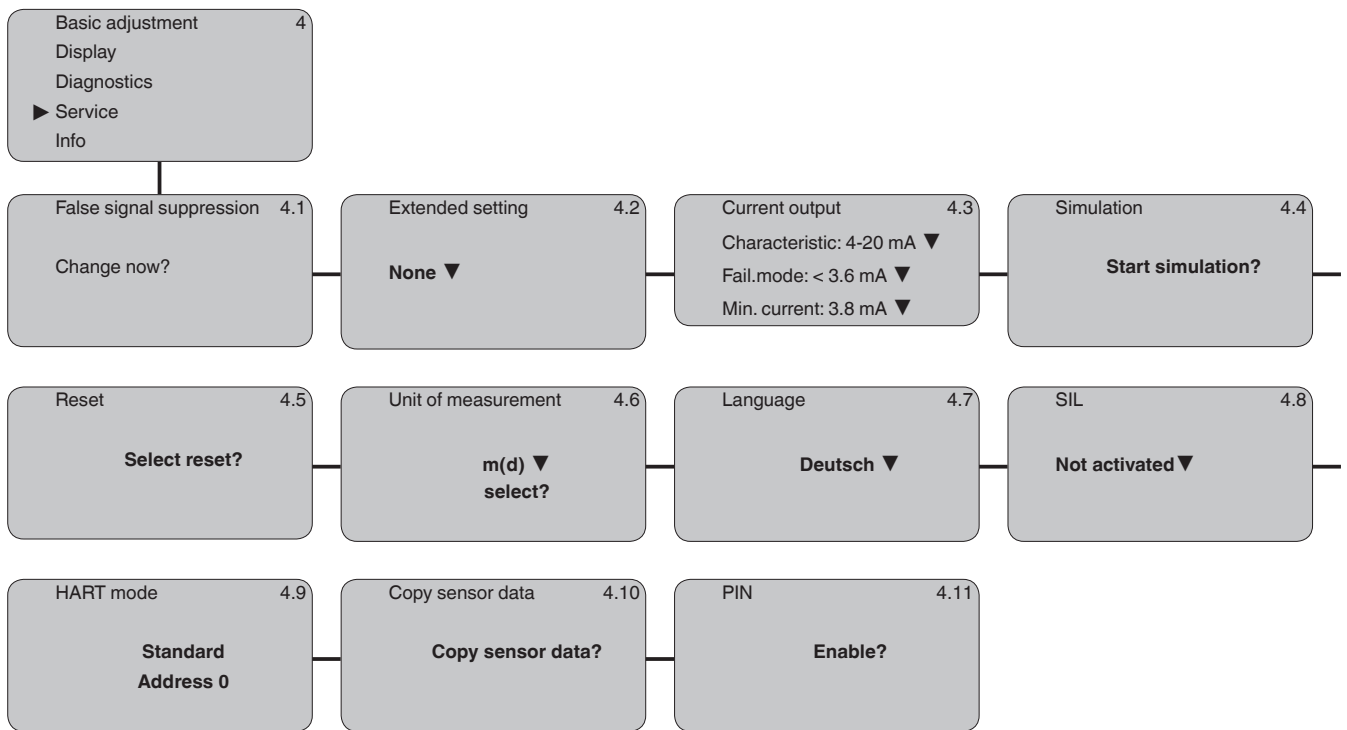

Info

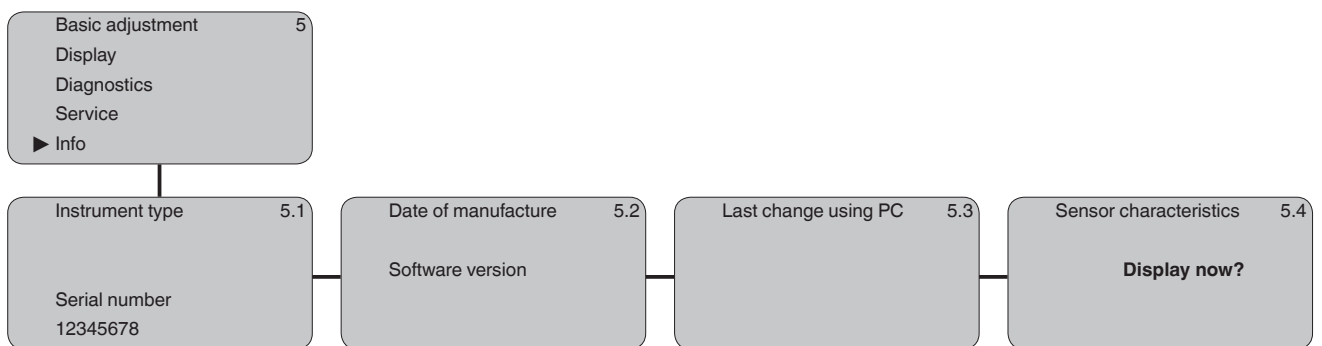

6.9 Saving the parameterisation data

We recommended writing down the adjustment data, e.g. in this operating instructions manual, and archiving them afterwards. They are thus available for multiple use or service purposes.

If VEGASON 61 is equipped with a display and adjustment module, the most important data can be read out of the sensor into the display and adjustment module. The procedure is described in the operating instructions manual "*Display and adjustment module*" in the menu item "*Copy sensor data*". The data remain there permanently even if the sensor power supply fails.

If it is necessary to exchange the sensor, the display and adjustment module is inserted into the replacement instrument and the data are written into the sensor under the menu item "*Copy sensor data*".

7 Set up with PACTware and other adjustment programs

7.1 Connect the PC via VEGACONNECT

VEGACONNECT directly on the sensor

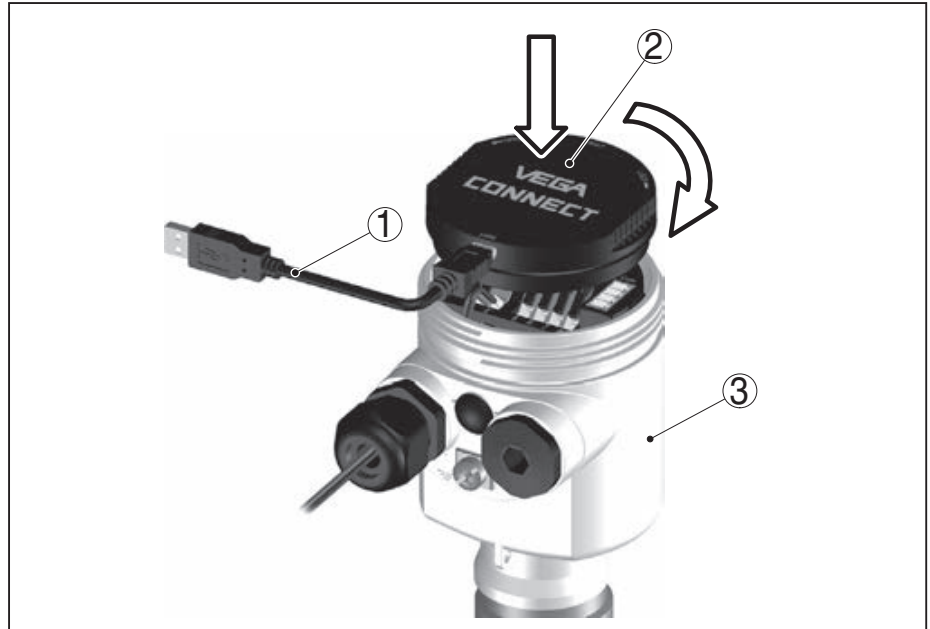

Fig. 30: Connection of the PC via VEGACONNECT directly to the sensor

- 1 USB cable to the PC
- 2 VEGACONNECT
- 3 Sensor

VEGACONNECT externally

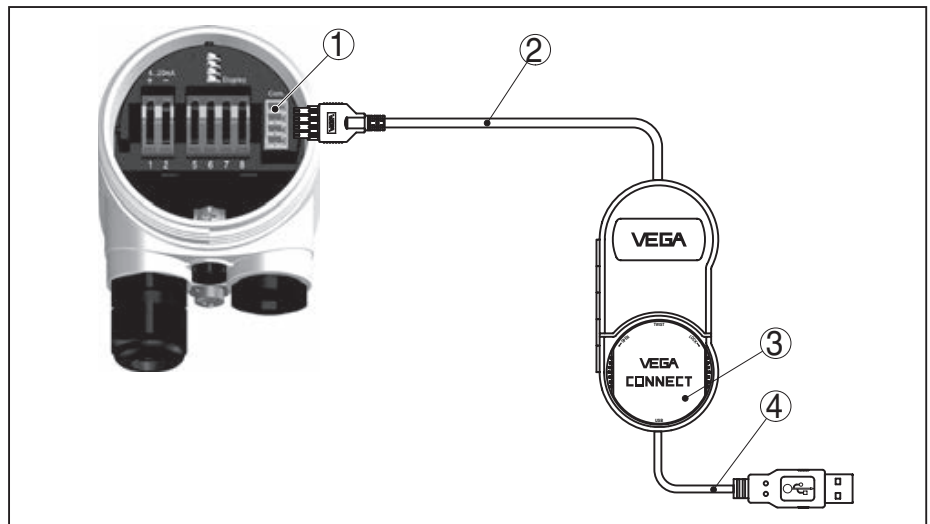

Fig. 31: Connection via VEGACONNECT externally

- 1 I²C bus (com.) interface on the sensor
- 2 I²C connection cable of VEGACONNECT
- 3 VEGACONNECT
- 4 USB cable to the PC

Necessary components:

- VEGASON 61
- PC with PACTware and suitable VEGA DTM

- VEGACONNECT
- Power supply unit or processing system

VEGACONNECT via HART

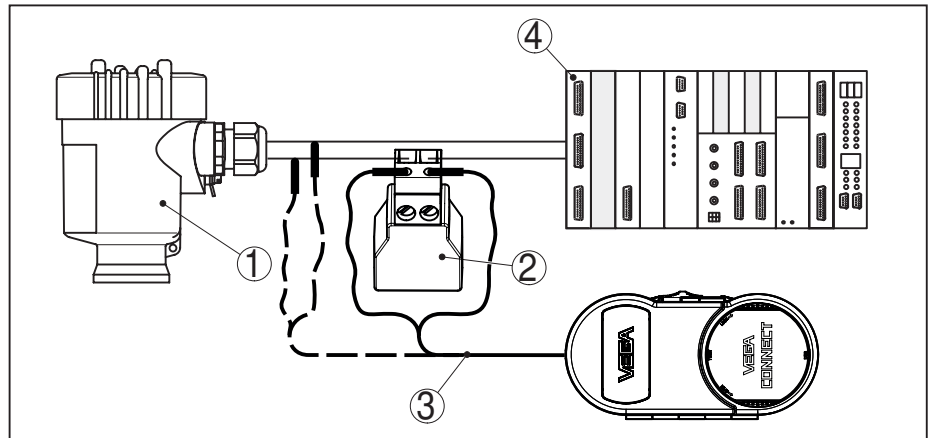

Fig. 32: Connecting the PC via HART to the signal cable

- 1 VEGASON 61
- 2 HART resistance 250 Ω (optional depending on evaluation)
- 3 Connection cable with 2 mm pins and terminals
- 4 Processing system/PLC/Voltage supply

Necessary components:

- VEGASON 61
- PC with PACTware and suitable VEGA DTM
- VEGACONNECT
- HART resistance approx. 250 Ω
- Power supply unit or processing system



Note:

With power supply units with integrated HART resistance (internal resistance approx. 250 Ω), an additional external resistance is not necessary. This applies, e. g. to the VEGA instruments VEGATRENN 149A, VEGADIS 371, VEGAMET 381. Common Ex separators are also usually equipped with a sufficient current limitation resistance. In such cases, VEGACONNECT 4 can be connected parallel to the 4 ... 20 mA cable.

7.2 Parameter adjustment with PACTware

Prerequisites

For parameter adjustment of the instrument via a Windows PC, the configuration software PACTware and a suitable instrument driver (DTM) according to FDT standard are required. The latest PACTware version as well as all available DTMs are compiled in a DTM Collection. The DTMs can also be integrated into other frame applications according to FDT standard.



Note:

To ensure that all instrument functions are supported, you should always use the latest DTM Collection. Furthermore, not all described functions are included in older firmware versions. You can download the latest instrument software from our homepage. A description of the update procedure is also available in the Internet.

Further setup steps are described in the operating instructions manual "DTM Collection/PACTware" attached to each DTM Collection and which can also be downloaded from the Internet. Detailed descriptions are available in the online help of PACTware and the DTMs.

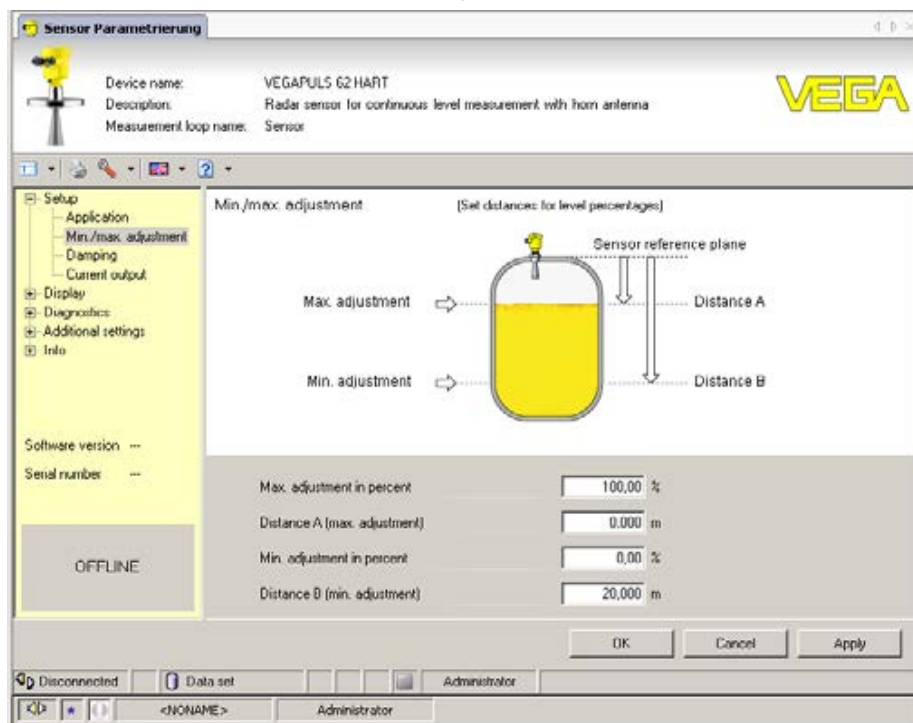

Fig. 33: Example of a DTM view

Standard/Full version

All device DTMs are available as a free-of-charge standard version and as a full version that must be purchased. In the standard version, all functions for complete setup are already included. An assistant for simple project configuration simplifies the adjustment considerably. Saving/printing the project as well as import/export functions are also part of the standard version.

In the full version there is also an extended print function for complete project documentation as well as a save function for measured value and echo curves. In addition, there is a tank calculation program as well as a multiviewer for display and analysis of the saved measured value and echo curves.

The standard version is available as a download under www.vega.com/downloads. The full version is available on CD from the agency serving you.

7.3 Parameter adjustment with AMS™ and PDM

For VEGA sensors, instrument descriptions for the adjustment programs AMS™ and PDM are available as DD or EDD. The instrument descriptions are already implemented in the current versions of AMS™ and PDM.

For older versions of AMS™ and PDM, a free-of-charge download is available via Internet. Move to www.vega.com.

7.4 Saving the parameterisation data

It is recommended to document or save the parameter adjustment data. That way they are available for multiple use or service purposes. The VEGA DTM Collection and PACTware in the licensed, professional version provide suitable tools for systematic project documentation and storage.

8 Maintenance and fault rectification

8.1 Maintenance

Maintenance

If the device is used properly, no special maintenance is required in normal operation.

Cleaning

The cleaning helps that the type label and markings on the instrument are visible.

Take note of the following:

- Use only cleaning agents which do not corrode the housings, type label and seals
- Use only cleaning methods corresponding to the housing protection rating

8.2 Rectify faults

Reaction when malfunction occurs

The operator of the system is responsible for taking suitable measures to rectify faults.

Causes of malfunction

The device offers maximum reliability. Nevertheless, faults can occur during operation. These may be caused by the following, e.g.:

- Sensor
- Process
- Voltage supply
- Signal processing

Fault rectification

The first measures to be taken are to check the output signals as well as to evaluate the error messages via the display and adjustment module. The procedure is described below. Further comprehensive diagnostics can be carried out on a PC with the software PACTware and the suitable DTM. In many cases, the causes can be determined and the faults rectified this way.

24 hour service hotline

Should these measures not be successful, please call in urgent cases the VEGA service hotline under the phone no. **+49 1805 858550**.

The hotline is manned 7 days a week round-the-clock. Since we offer this service worldwide, the support is only available in the English language. The service is free, only standard call charges are incurred.

Check the 4 ... 20 mA signal

Connect a multimeter in the suitable measuring range according to the wiring plan. The following table describes possible errors in the current signal and helps to eliminate them:

Error	Cause	Rectification
4 ... 20 mA signal not stable	Level fluctuations	Set damping via the display and adjustment module

Error	Cause	Rectification
4 ... 20 mA signal missing	Electrical connection faulty	Check connection according to chapter " <i>Connection steps</i> " and if necessary, correct according to chapter " <i>Wiring plan</i> "
	Voltage supply missing	Check cables for breaks; repair if necessary
	Operating voltage too low or load resistance too high	Check, adapt if necessary
Current signal greater than 22 mA or less than 3.6 mA	Electronics module in the sensor defective	Exchange the instrument or send it in for repair



In Ex applications, the regulations for the wiring of intrinsically safe circuits must be observed.

Error messages via the display and adjustment module

Error	Cause	Rectification
E013	no measured value available	Sensor in boot phase Sensor does not find an echo, e.g. due to faulty installation or wrong parameter adjustment
E017	Adjustment span too small	Carry out a fresh adjustment and increase the distance between min. and max. adjustment
E036	no operable sensor software	Carry out a software update or send instrument for repair
E041	Hardware error, electronics defective	Exchange the instrument or send it in for repair

Reaction after fault rectification

Depending on the reason for the fault and the measures taken, the steps described in chapter "*Set up*" may have to be carried out again.

8.3 Exchanging the electronics module

If the electronics module is defective, it can be replaced by the user.



In Ex applications, only instruments and electronics modules with appropriate Ex approval may be used.

If there is no electronics module available on site, one can be ordered from the VEGA agency serving you.

Sensor serial number

The new electronics module must be loaded with the settings of the sensor. These are the options:

- At the factory by VEGA
- Or on site by the user

In both cases, the sensor serial number is necessary. The serial numbers are stated on the type label of the instrument, inside the housing or on the delivery note.



Information:

When loading on site, the order data must first be downloaded from the Internet (see operating instructions "*Electronics module*").

Assignment

The electronics modules are adapted to the respective sensor and distinguish also in the signal output or power supply.

8.4 Software update

The following components are required to update the instrument software:

- Instrument
- Voltage supply
- Interface adapter VEGACONNECT
- PC with PACTware
- Current instrument software as file

You can find the current instrument software as well as detailed information on the procedure in the download area of our homepage: www.vega.com.

**Caution:**

Instruments with approvals can be bound to certain software versions. Therefore make sure that the approval is still effective after a software update is carried out.

You can find detailed information in the download area at www.vega.com.

8.5 How to proceed if a repair is necessary

You can find an instrument return form as well as detailed information about the procedure in the download area of our homepage: www.vega.com.

By doing this you help us carry out the repair quickly and without having to call back for needed information.

If a repair is necessary, please proceed as follows:

- Print and fill out one form per instrument
- Clean the instrument and pack it damage-proof
- Attach the completed form and, if need be, also a safety data sheet outside on the packaging
- Please contact the agency serving you to get the address for the return shipment. You can find the agency on our home page www.vega.com.

9 Dismount

9.1 Dismounting steps

**Warning:**

Before dismounting, be aware of dangerous process conditions such as e.g. pressure in the vessel or pipeline, high temperatures, corrosive or toxic products etc.

Take note of chapters "*Mounting*" and "*Connecting to voltage supply*" and carry out the listed steps in reverse order.

9.2 Disposal

The instrument consists of materials which can be recycled by specialised recycling companies. We use recyclable materials and have designed the electronics to be easily separable.

WEEE directive

The instrument does not fall in the scope of the EU WEEE directive. Article 2 of this Directive exempts electrical and electronic equipment from this requirement if it is part of another instrument that does not fall in the scope of the Directive. These include stationary industrial plants.

Pass the instrument directly on to a specialised recycling company and do not use the municipal collecting points.

If you have no way to dispose of the old instrument properly, please contact us concerning return and disposal.

10 Supplement

10.1 Technical data

Note for approved instruments

The technical data in the respective safety instructions are valid for approved instruments (e.g. with Ex approval). These data can differ from the data listed herein, for example regarding the process conditions or the voltage supply.

General data

Materials, wetted parts

– Transducer	PVDF
– Seal transducer/process fitting	EPDM, FKM
– Process fitting G1½, DIN 3852-A-B	PVDF
– Process fitting 1½ NPT, ASME B1.20.1	PVDF

Materials, non-wetted parts

– Housing	Plastic PBT (polyester), Alu die-casting, powder-coated, 316L
– Seal, housing lid	Silicone SI 850 R
– Inspection window housing cover	Polycarbonate (UL-746-C listed), glass ⁸⁾
– Ground terminal	316Ti/316L
– Cable gland	PA, stainless steel, brass
– Sealing, cable gland	NBR
– Blind plug, cable gland	PA

Weight 1.8 ... 4 kg (4 ... 8.8 lbs), depending on the process fitting and housing

Max. torque mounting boss 25 Nm (18.44 lbf ft)

Input variable

Measured variable distance between lower edge of the transducer and product surface

Measuring range

– Liquids	up to 5 m (16.4 ft)
– Bulk solids	up to 2 m (6.562 ft)

Dead zone 0.25 m (0.82 ft)

Output variable

Output signal 4 ... 20 mA/HART

HART output values

– HART value (Primary Value)	Distance to the level
– HART value (Secondary Value)	Temperature
– HART value (3rd Value)	Distance to the level - scaled

⁸⁾ Glass (with Aluminium and stainless steel precision casting housing)

Signal resolution	1.6 μ A
Resolution, digital	1 mm (0.039 in)
Fault signal, current output (adjustable)	mA-value unchanged 20.5 mA, 22 mA, < 3.6 mA
Current limitation	22 mA
Load	see load diagram under Power supply
Damping (63 % of the input variable)	0 ... 999 s, adjustable
Met NAMUR recommendation	NE 43

Deviation

Deviation⁹⁾ \leq 4 mm (meas. distance > 2.0 m/6.562 ft)

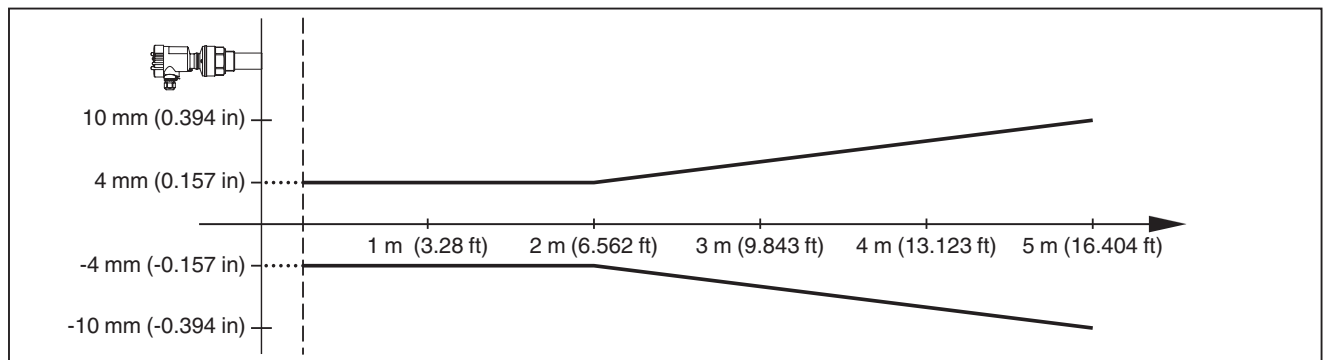

Fig. 34: Deviation VEGASON 61

Reference conditions to measurement accuracy (according to DIN EN 60770-1)

Reference conditions according to DIN EN 61298-1

- Temperature +18 ... +30 °C (+64 ... +86 °F)
- Relative humidity 45 ... 75 %
- Air pressure 860 ... 1060 mbar/86 ... 106 kPa (12.5 ... 15.4 psig)

Other reference conditions

- Reflector ideal reflector, e.g. metal plate 2 x 2 m (6.56 x 6.56 ft)
- False reflections Biggest false signal, 20 dB smaller than the useful signal

Measuring characteristics

Ultrasonic frequency	70 kHz
Interval	> 2 s (dependent on the parameter adjustment)
Abstrahlwinkel at -3 dB	11°
Step response or adjustment time ¹⁰⁾	> 3 s (dependent on the parameter adjustment)

Influence of the ambient temperature to the sensor electronics¹¹⁾

Average temperature coefficient of the zero signal (temperature error) 0.06 %/10 K

⁹⁾ Incl. non-linearity, hysteresis and non-repeatability.

¹⁰⁾ Time to output the correct level (with max. 10 % deviation) after a sudden level change.

¹¹⁾ Relating to the nominal measuring range.

Ambient conditions

Ambient, storage and transport temperature -40 ... +80 °C (-40 ... +176 °F)

Process conditions

Process pressure -20 ... 200 kPa/-0.2 ... 2 bar (-2.9 ... 29 psig)

Process temperature (transducer temperature)

– Seal EPDM -40 ... +80 °C (-40 ... +176 °F)

– Seal FKM -20 ... +80 °C (-4 ... +176 °F)

Vibration resistance mechanical vibrations with 4 g and 5 ... 100 Hz¹²⁾

Electromechanical data - version IP 66/IP 67 and IP 66/IP 68 (0.2 bar)

Options of the cable entry

– Cable entry M20 x 1.5; ½ NPT

– Cable gland M20 x 1.5; ½ NPT

– Blind plug M20 x 1.5; ½ NPT

– Closing cap ½ NPT

Wire cross-section (spring-loaded terminals)

– Massive wire, stranded wire 0.2 ... 2.5 mm² (AWG 24 ... 14)

– Stranded wire with end sleeve 0.2 ... 1.5 mm² (AWG 24 ... 16)

Electromechanical data - version IP 66/IP 68 (1 bar)

Options of the cable entry

– Cable gland with integrated connection cable M20 x 1.5 (cable: ø 5 ... 9 mm)

– Cable entry ½ NPT

– Blind plug M20 x 1.5; ½ NPT

Connection cable

– Wire cross-section 0.5 mm² (AWG 20)

– Wire resistance < 0.036 Ω/m

– Tensile strength < 1200 N (270 lbf)

– Standard length 5 m (16.4 ft)

– Max. length 180 m (590.6 ft)

– Min. bending radius 25 mm (0.984 in) with 25 °C (77 °F)

– Diameter approx. 8 mm (0.315 in)

– Colour - Non-Ex version Black

– Colour - Ex-version Blue

Display and adjustment module

Voltage supply and data transmission through the sensor

Indication LC display in dot matrix

Adjustment elements 4 keys

¹²⁾ Tested according to the guidelines of German Lloyd, GL directive 2.

Protection rating

- unassembled IP 20
- Mounted into the sensor without cover IP 40

Ambient temperature - Display and adjustment module -20 ... +70 °C (-4 ... +158 °F)

Material

- Housing ABS
- Inspection window Polyester foil

Voltage supply

Operating voltage

- Non-Ex instrument 14 ... 35 V DC
- Ex-ia instrument 14 ... 30 V DC

Operating voltage U_B with lighting switched on

- Non-Ex instrument 20 ... 35 V DC
- Ex-ia instrument 20 ... 30 V DC

Permissible residual ripple

- < 100 Hz $U_{ss} < 1 V$
- 100 Hz ... 10 kHz $U_{ss} < 10 mV$

Load resistor

- Calculation $(U_B - U_{min})/0.022 A$
- Example - Non-Ex instrument with $U_B = 24 V DC$
 $(24 V - 14 V)/0.022 A = 455 \Omega$

Electrical protective measures

Protection rating

Housing material	Version	IP-protection class	NEMA protection
Plastic	Single chamber	IP 66/IP 67	Type 4X
	Double chamber	IP 66/IP 67	Type 4X
Aluminium	Single chamber	IP 66/IP 68 (0.2 bar)	Type 6P
		IP 68 (1 bar)	Type 6P
	Double chamber	IP 66/IP 67	Type 4X
		IP 66/IP 68 (0.2 bar) IP 68 (1 bar)	Type 6P Type 6P
Stainless steel (electro-polished)	Single chamber	IP 66/IP 68 (0.2 bar)	Type 6P
Stainless steel (precision casting)	Single chamber	IP 66/IP 68 (0.2 bar) IP 68 (1 bar)	Type 6P Type 6P

Connection of the feeding power supply unit Networks of overvoltage category III

28775-EN-190318

Altitude above sea level

- by default up to 2000 m (6562 ft)
- with connected overvoltage protection up to 5000 m (16404 ft)

Pollution degree¹³⁾ 4

Protection class II (IEC 61010-1)

Functional safety (SIL)

Functional safety is already activated on instruments with SIL qualification ex factory. On instruments without SIL qualification ex factory, the functional safety must be activated by the user via the display and adjustment module or via PACTware for applications according to SIL.

Functional safety according to IEC 61508-4

- Single channel architecture (1oo1D) up to SIL2
- double channel diversitary redundant architecture (1oo2D) up to SIL3

You can find detailed information in the supplied Safety Manual of the instrument series or under "www.vega.com", "*Downloads*", "*Approvals*".

Approvals

Instruments with approvals can have different technical specifications depending on the version.

For that reason the associated approval documents of these instruments have to be carefully noted. They are part of the delivery or can be downloaded by entering the serial number of your instrument into the search field under www.vega.com as well as in the general download area.

¹³⁾ When used with fulfilled housing protection

10.2 Dimensions

Housing in protection IP 66/IP 68 (0.2 bar)

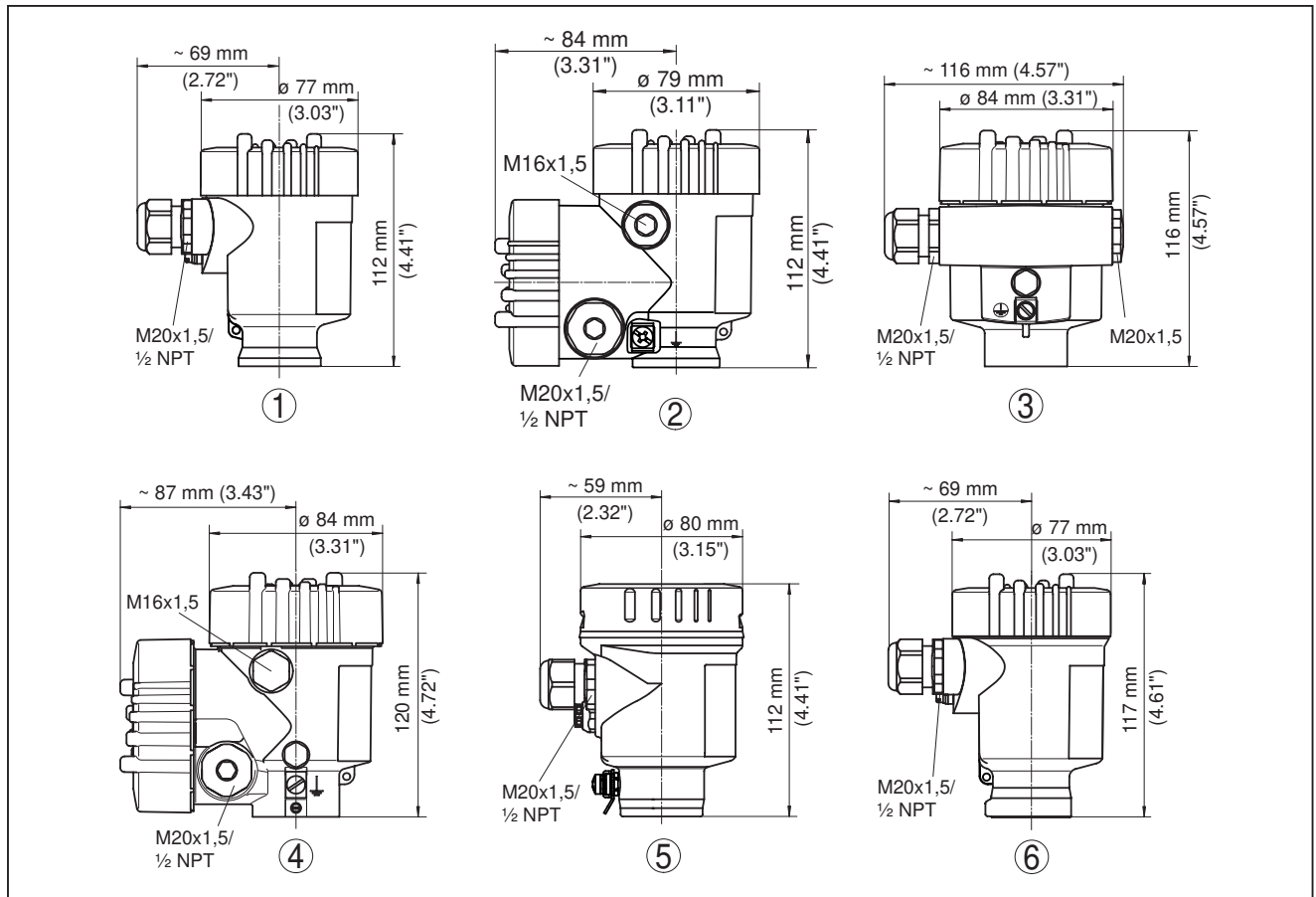

Fig. 35: Housing versions with protection rating IP 66/IP 68 (0.2 bar), (with integrated display and adjustment module the housing is 9 mm/0.35 in higher, with metal housings 18 mm/0.71 in)

- 1 Plastic single chamber (IP 66/IP 67)
- 2 Plastic double chamber
- 3 Aluminium - single chamber
- 4 Aluminium - double chamber
- 5 Stainless steel single chamber (electropolished)
- 6 Stainless steel single chamber (precision casting)

Housing in protection IP 66/IP 68 (1 bar)

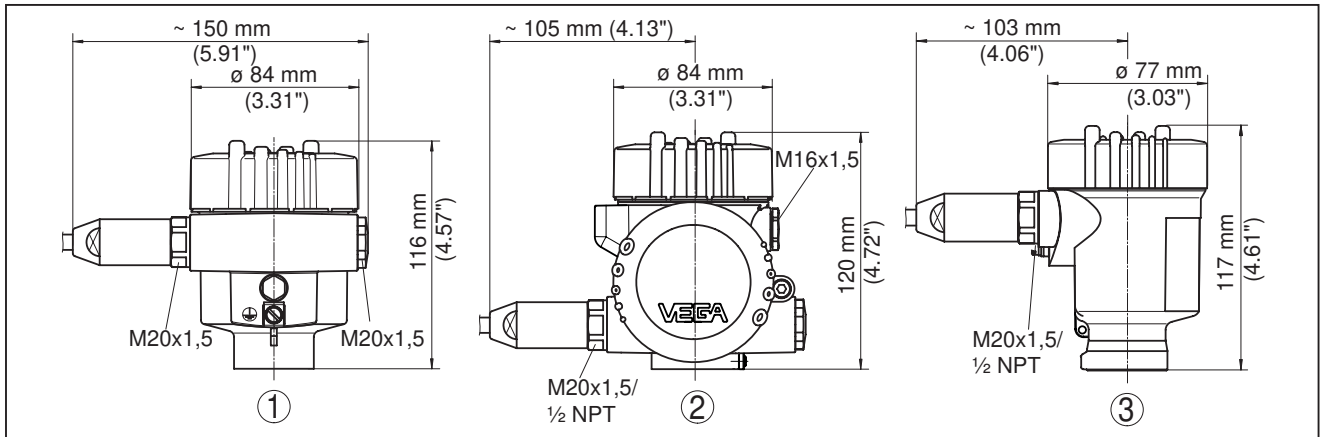

Fig. 36: Housing version with protection rating IP 66/IP 68 (1 bar), (with integrated display and adjustment module the housing is 18 mm/0.71 in higher)

- 1 Aluminium - single chamber
- 2 Aluminium - double chamber
- 3 Stainless steel single chamber (precision casting)

VEGASON 61

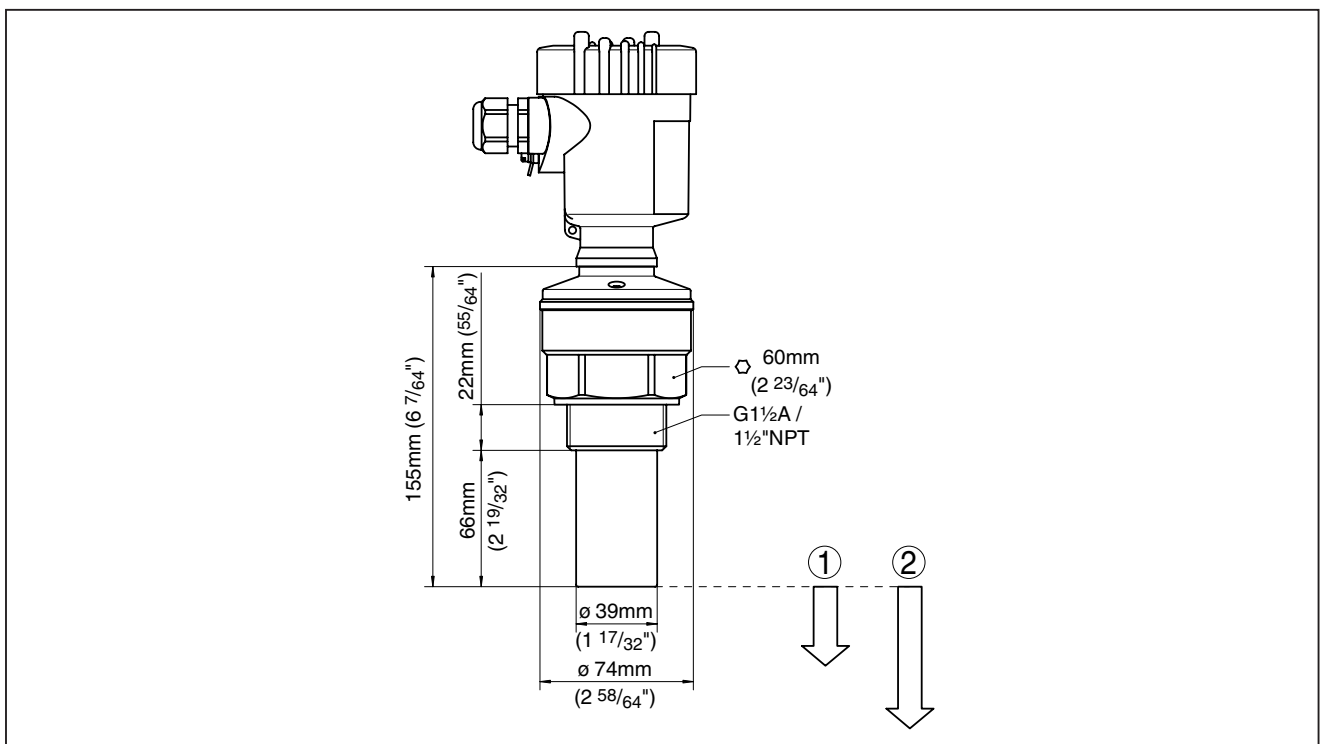

Fig. 37: VEGASON 61

- 1 Dead zone: 0.25 m (0.82 ft)
- 2 Measuring range: with liquids up to 5 m (16.4 ft), with solids up to 2 m (6.562 ft)

10.3 Industrial property rights

VEGA product lines are global protected by industrial property rights. Further information see www.vega.com.

VEGA Produktfamilien sind weltweit geschützt durch gewerbliche Schutzrechte.

Nähere Informationen unter www.vega.com.

Les lignes de produits VEGA sont globalement protégées par des droits de propriété intellectuelle. Pour plus d'informations, on pourra se référer au site www.vega.com.

VEGA lineas de productos están protegidas por los derechos en el campo de la propiedad industrial. Para mayor información revise la pagina web www.vega.com.

Линии продукции фирмы ВЕГА защищаются по всему миру правами на интеллектуальную собственность. Дальнейшую информацию смотрите на сайте www.vega.com.

VEGA系列产品在全球享有知识产权保护。

进一步信息请参见网站<www.vega.com>。

10.4 Trademark

All the brands as well as trade and company names used are property of their lawful proprietor/originator.



Printing date:

All statements concerning scope of delivery, application, practical use and operating conditions of the sensors and processing systems correspond to the information available at the time of printing.

Subject to change without prior notice

© VEGA Grieshaber KG, Schiltach/Germany 2019



28775-EN-190318

VEGA Grieshaber KG
Am Hohenstein 113
77761 Schiltach
Germany

Phone +49 7836 50-0
Fax +49 7836 50-201
E-mail: info.de@vega.com
www.vega.com