

FT17 Series-hand-to-self integrated water mixing center electric ball valve

Product Overview

It is widely used for heating and ventilation, on-off control of water supply system, built-in travel limit switch, which can make the valve power off when it is fully open or closed, and can automatically reset when it is powered off.

Product Features

- Within a certain size, the structure is simple and the operation is simple.
- Light weight, small installation space
- Has the lowest flow resistance
- Large torque and short action time
- The valve body is symmetrical and suitable for high pressure resistant occasions.

Driver parameters

Motor type	Synchronous machine	Power cord length	300mm
Action Time	~10S	Torque	7N.m
Close differential pressure	≤0.6Mpa	Nominal pressure	PN16~PN20
Medium temperature	15~95°C		
Watt consumption	50/60Hz 2W(Only when the valve is open)		
Applicable media	Cold, hot water or 50% ethanol solution		
Electrical specifications	AC/DC100-230V AC/DC9-30V		
Operating angle	0°/90°		

Valve body parameters

Product specifications	Caliber	Product Size (mm)			Kv Value M/H	Net Weigh KG
		H	L	L1		
Two-way	D N 15(1/2)	110	50		12	0.15
	D N 20(3/4)	117	55		17	0.21
	D N 25(1)	120	65		20	0.3
	D N 32(1-1/4)	122	74		25	0.54
	D N 40(1-1/2)	124	82		31	0.6
Three-way	D N 15(1/2)	106	56	42	12	0.21
	D N 20(3/4)	115	68	52	17	0.35
	D N 25(1)	120	83	64	20	0.54

Photo illustration

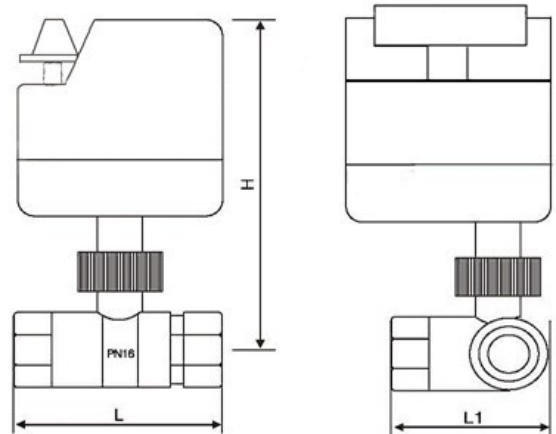

Product Type

Product Model	Demonstration of the type
FT17-21	Power-off automatic reset AC/DC 100-230V AC/DC 9-30V
FT17-31/32	Three lines and one control AC220V

Wiring diagram

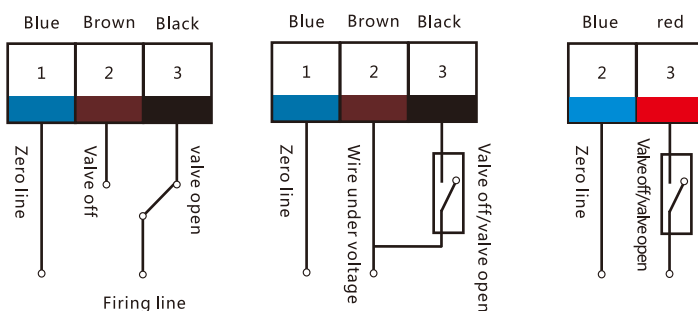

three line two

Three-line one control
(normally on/normally off)

Line (normally open/
normally closed type)

Selection description

