

Modular type Air Unit(AW+AL)

Filter regulator + Lubricator



◆ SAU2010M~6010M Series

· SAU series are compact type assemblies of a filter regulator and a lubricator. SAU series are most suitable to spatial application by minimizing occupied space of machinery.

● How to order

SAU 30 10 M- 03 DG- Me

- 1 Air Unit
- 2 Body Size
 - 20 - 1/4
 - 30 - 3/8
 - 40 - 1/2
 - 60 - 1
- 3 Composition
 - 00 - AF+AR+AL
 - 10 - AW+AL
 - 20 - AF+AR
 - 30 - AF+AFM+AR
 - 40 - AW+AFM
 - 50 - AFM+AFD+AR
 - 60 - AW+AFM+AFD
- 4 Port Size
 - 02 - Rc(PT) 1/4 "
 - 03 - Rc(PT) 3/8 "
 - 04 - Rc(PT) 1/2 "
 - 06 - Rc(PT) 3/4 "
 - 10 - Rc(PT) 1 "
- 5 Accessory(Optional)
 - Nil - Manual Drain
 - D - Auto Drain
 - G - Gauge
- 6 Option
 - Nil - PC Bowl
 - Me - Metal Bowl



● Symbol

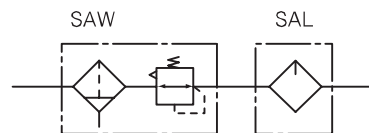

● Specification

Combination	Filter regulator Lubricator
Max. supply pressure	1.5MPa [15.3 kgf/cm ²]
Max. operating pressure	0.97MPa [9.9 kgf/cm ²]
Regulating range	50~850kPa [0.5~8.7 kgf/cm ²]
Ambient and media temperature	5 ~ 60℃
Filtration	Standard:10μm, Option:2, 5, 20, 40
Recommended oil	Turbin oil (ISO VG32)
Bowl material	Poly-carbonate · Metal
Construction / Filter regulator	Relief type

● Precautions

- ① Poly-carbonate bowls may be damaged and highly possible to fail if exposed to synthetic oils, thinner solvents, trichloroethylene, kerosene, chloroform, cyclohexane or other aromatic hydrocarbons and such environment exposed chemicals such as above.
- ② When auto drain is used :
Drain piping should be both 4mm or greater in diameter and less than 1m in length.
Also should avoid setting drain piping upwards.
- ③ When auto drain is out of order, it is possible to drain manually by operating one-touch-fitting vertically.
- ④ With a drain cock attached, drain can be done when the head of liquid is shown at the glass indication tube.

● STRUCTURE

SAU 2010M

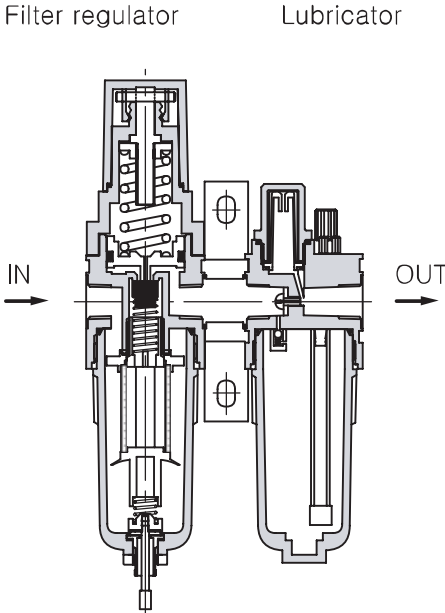

SAU 3010M

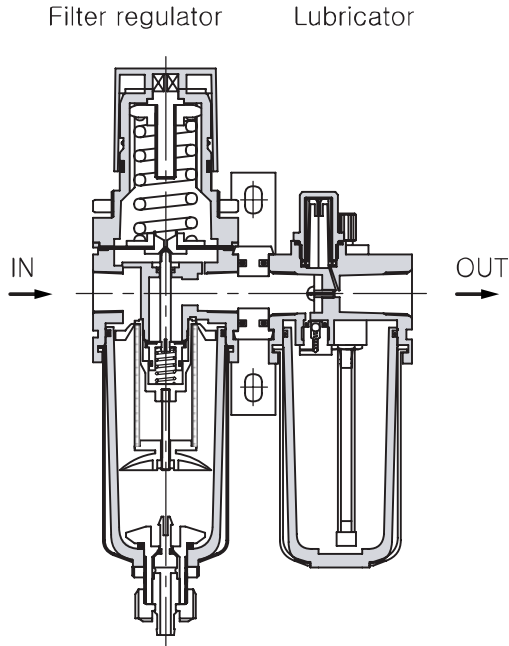

SAU

● STRUCTURE

SAU 4010M

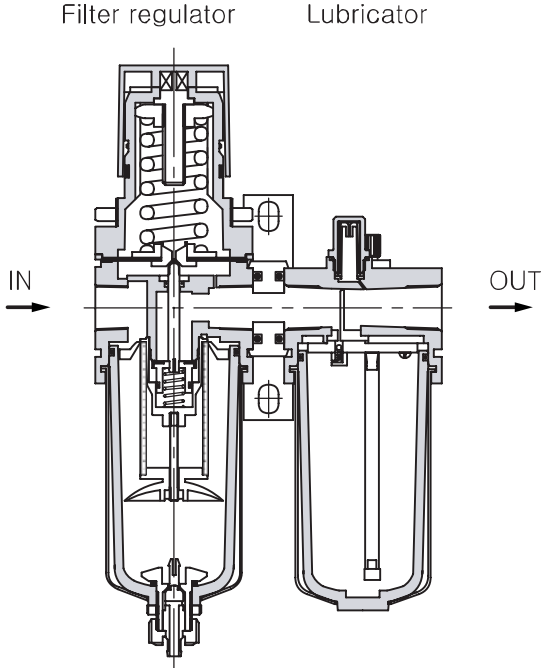

SAU 6010M

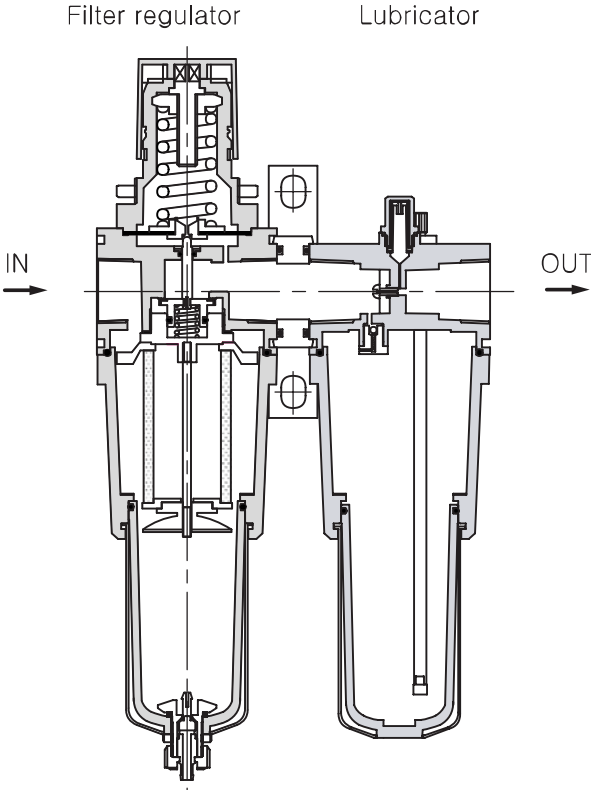

SAU

● DIMENSIONS(mm)

SAU 2010M

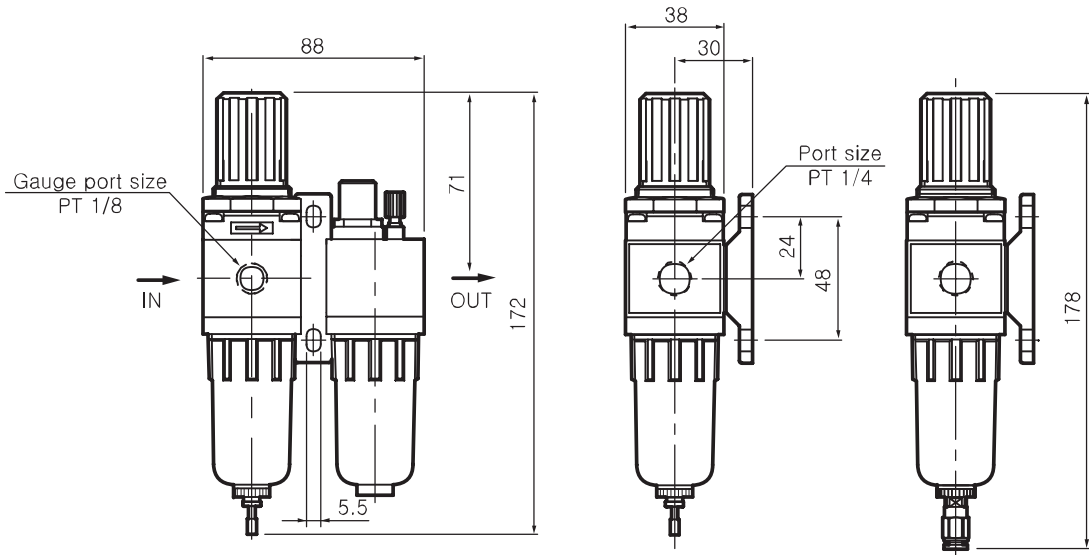

With differential pressure type auto drain

SAU 3010M

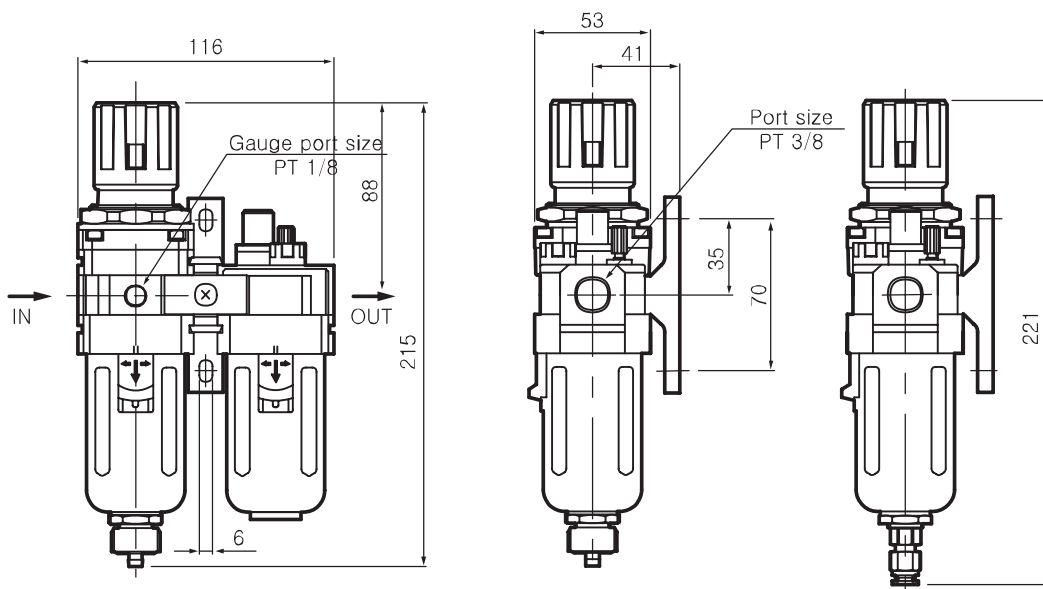

With float type auto drain

SAU

SAU(AW+AL) Series



● DIMENSIONS(mm)

SAU 4010M-04

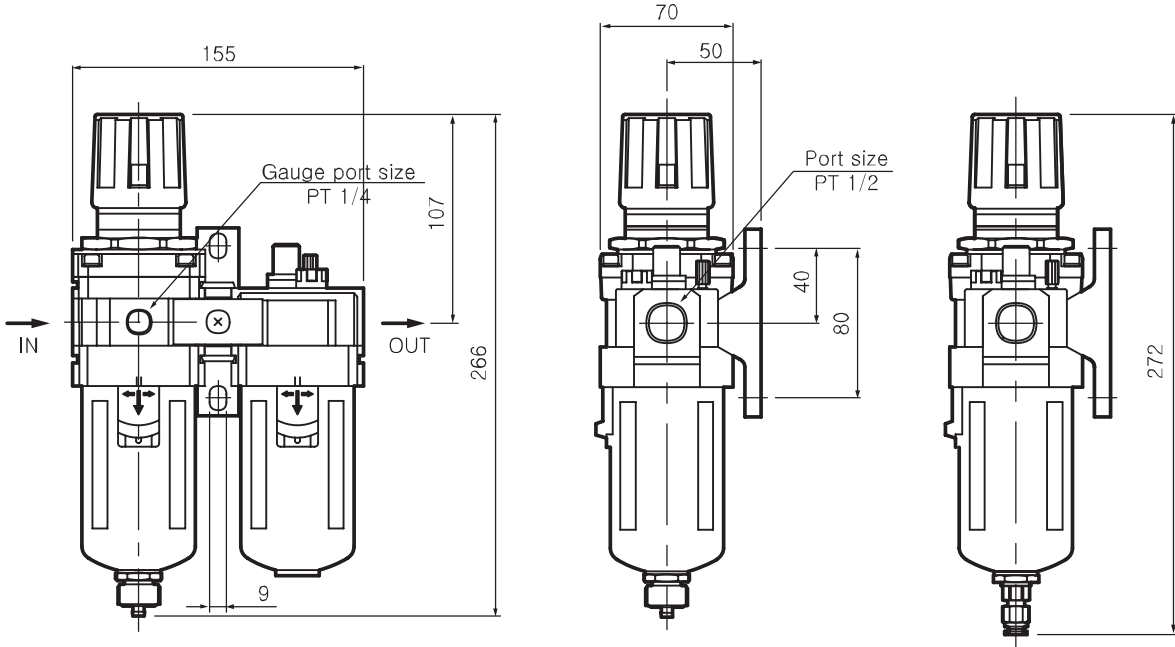

With float type auto drain

SAU 6010M

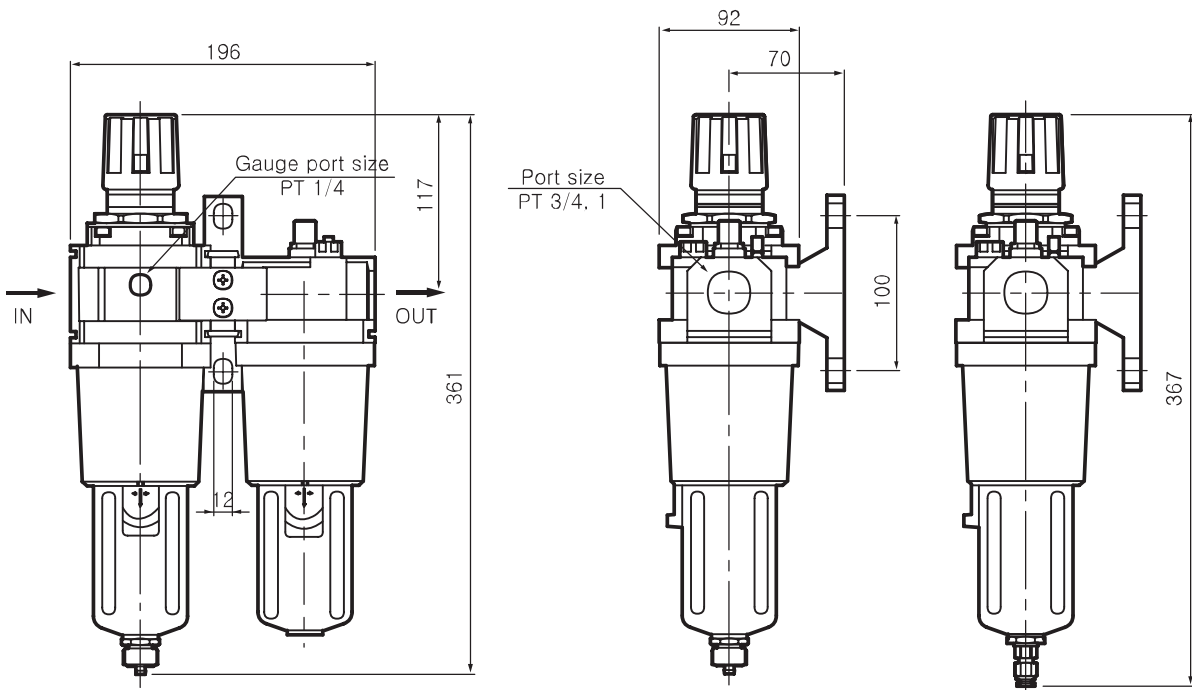

With float type auto drain

SAU

● DIMENSIONS(mm) – Metal Bowl

SAU 2010M-Me

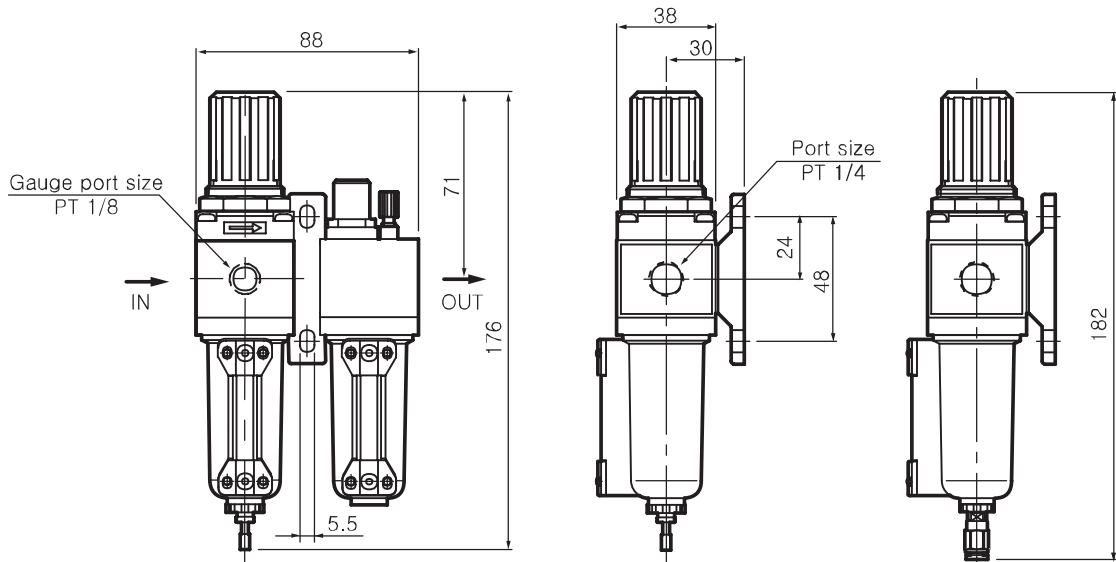

With differential pressure type auto drain

SAU 3010M-Me

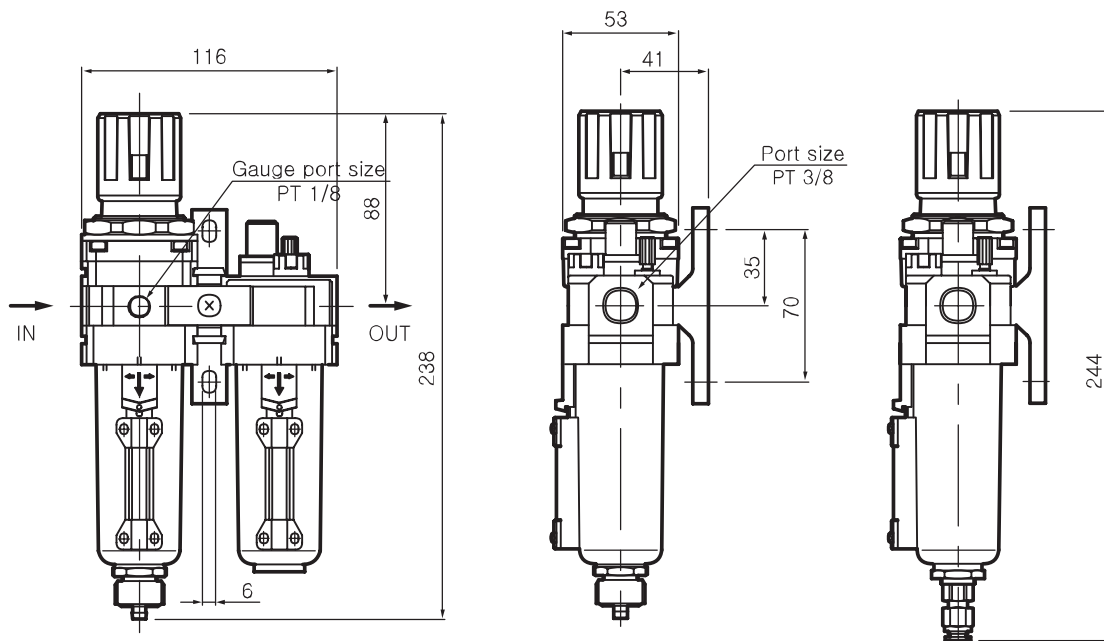

With float type auto drain

SAU

SAU(AW+AL) Series



● DIMENSIONS(mm) – Metal Bowl

SAU 4010M-04-Me

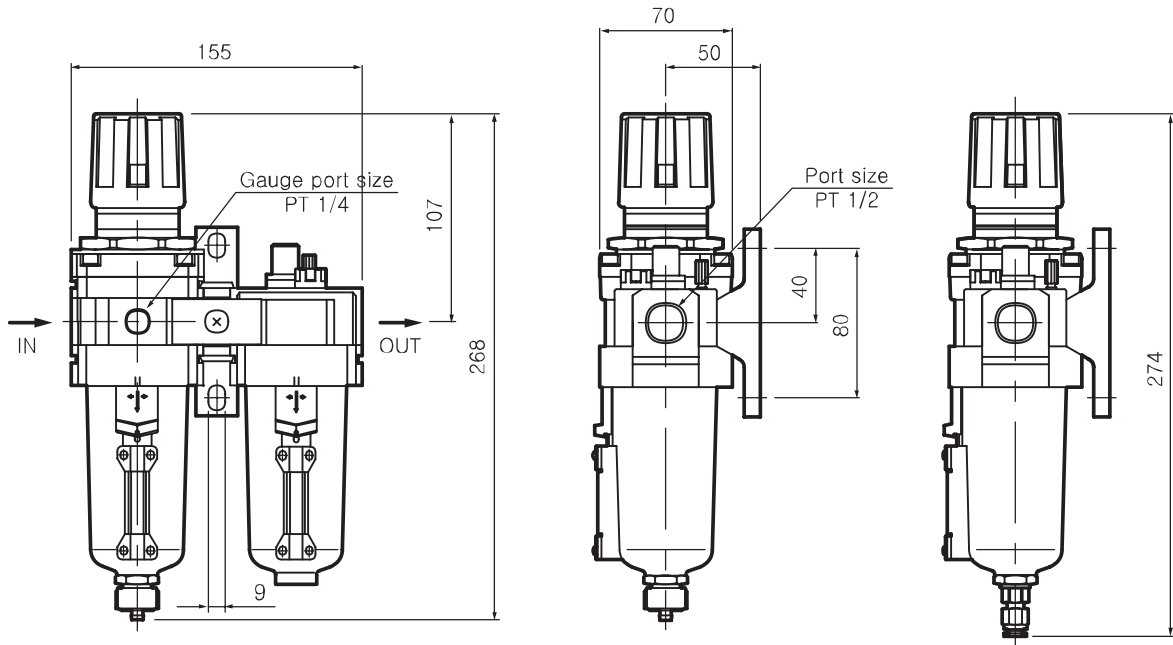

With float type auto drain

SAU 6010M-Me

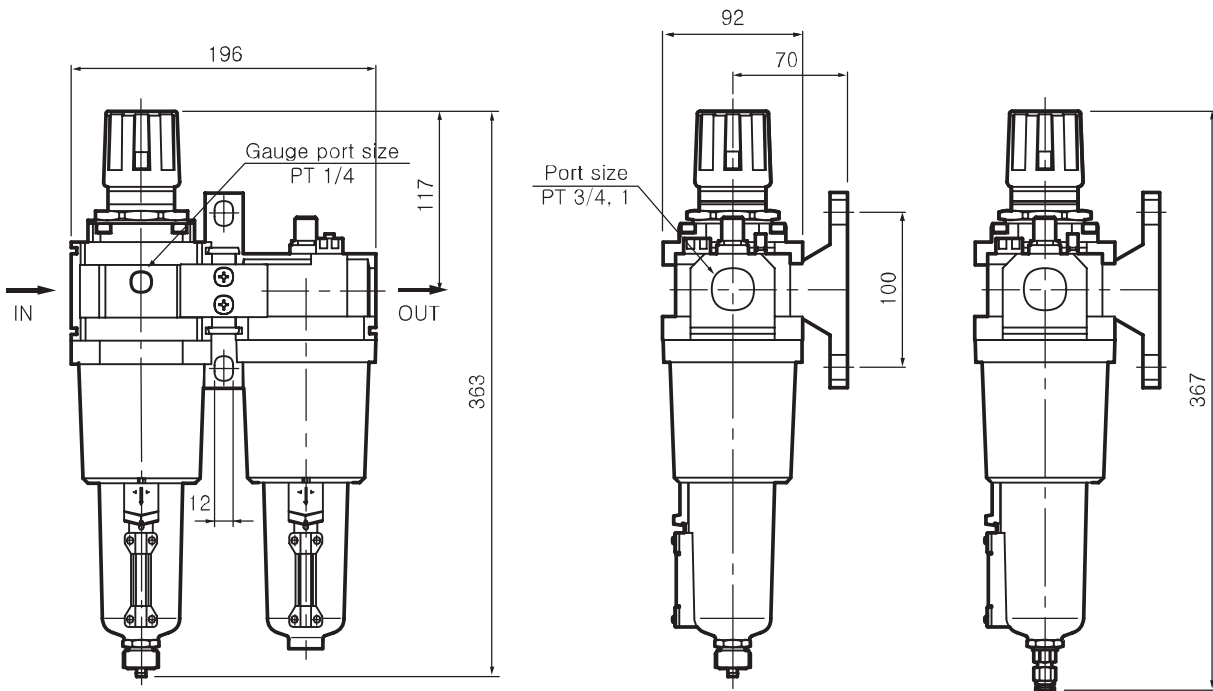

With float type auto drain

SAU